

Excel-erator

Programmer's Guide and Reference
Licensed Program 2A55XL1 V1R8M0



Data Base Conversion

Edition

Eight Edition (March 2011)

This edition applies to the licensed program Excel-erator (Program 2A55XL1), Version 1 Release 8 Modification 0, and to all subsequent releases and modifications until otherwise indicated in new editions. This revision makes all previous editions obsolete. Make sure you are using the proper edition for the level of the product.

This manual is available as option 1 from the XLERATOR menu or in PDF format in directory /Gumbo/Proddata/2A55XL1/doc on your System i and on the web.

We welcome your comments. Send them to:

GUMBO
Software, Inc.

809 W Howe St
Seattle, WA 98119
United States of America
Phone: 206-284-5078
Email: support@gumbo.com
Web: www.gumbo.com

© Copyright Gumbo Software, Inc. 2001, 2011. All Rights Reserved.

Contents

Edition	ii	Changing Programs.....	29
Contents	iii	Manually Processing Files	30
Chapter 1 Introduction	5	Accessing Files In The Integrated File System	30
What's In This Chapter	5	Creating PDM Options For Excel-erator	33
Excel-erator Overview	5	Selecting Records With OPNQRYF	35
Excel-erator Feature.....	5	Using Format Codes In Headers And Footers	35
Standard Product Support Features.....	6	Email Addresses	35
Excel-erator's TOOBJ() Parameter	6	Adding Line Breaks to the Message.....	37
Product Positioning.....	7	Digitally Signing The Message	38
Future Directions	8	CL Coding Tip.....	38
Manual Conventions	8	Changing Command Defaults	38
Chapter 2 Installation	9	Chapter 6 Conversion	41
What's In This Chapter	9	What's In This Chapter	41
Installing Excel-erator	9	Overview.....	41
Verifying Excel-erator Installation	10	*BIFF8 Conversion Details and Limitations ..	42
Library List Considerations.....	11	*BIFF4 Conversion Details and Limitations ..	43
Release Considerations	11	*CSVUTF8 Conversion Details and	
New Release Testing	12	Limitations.....	44
Deleting Excel-erator.....	12	*CSVUTF8M Conversion Details and	
Additional Installation Information.....	13	Limitations.....	45
Technical Support	13	*CSVRFC Conversion Details and Limitations	
Hot Site Installation.....	13	45
Permanent Authorization Codes.....	14	*XMLSS Conversion Details and Limitations	
Chapter 3 Menu	17	45
What's In This Chapter	17	*OOXML Conversion Details and Limitations	
Accessing The Menu	17	46
Menu Options	17	Chapter 7 Commands	49
Chapter 4 Set Up	19	What's In This Chapter	49
What's In This Chapter	19	Change Excel-erator Authorization	
Selecting The Quick Start Mail Set Up		(CHGXL1AUT).....	50
Procedure.....	19	Change Excel-erator Default (CHGXL1DFT)52	
Quick Start Mail Set Up - Mail Router	20	Check Excel-erator Authorization	
Quick Start Mail Set Up - Direct Delivery	21	(CHKXL1AUT).....	53
Using The SMTP Set Up Command.....	22	Copy To Excel (CPYTOEXCEL).....	54
Using The Mail Router Set Up Command	22	Display Mail Log (DSPMAILLOG)	67
Manual Mail Set Up Steps You May Need To		Restart/Purge Local Mail (INZLOCAL).....	69
Perform.....	23	Ping SMTP Mail Server (PINGMAIL).....	71
Additional Mail Set Up Resources	27	Send File Excel (SNDFEXCEL).....	73
Chapter 5 Implementation	29	Verify/Set Up Local SMTP (VFYLOCAL).....	87
What's In This Chapter	29	Verify/Set Up Mail Router (VFYROUTER) ...	88
Overview.....	29	Chapter 8 Trouble-Shooting	91

What's In This Chapter	91
General Trouble-Shooting	91
Software Installation Problems	91
XLS File Problems	92
General Mail Delivery Problems	92
MSF Specific Delivery Problems.....	95
SMTP Specific Delivery Problems	96
Appendix A Process Descriptions..	97
What's In This Appendix	97
Processing Performed During SMTP Verification	97
Processing Performed During SMTP Set Up	98
Processing Performed During Mail Router Verification	100
Processing Performed During Mail Router Set Up	101
Appendix B Notices	104
Notices.....	104
Appendix C Order Form.....	105
Appendix D License Agreement ...	106

Chapter 1 Introduction

What's In This Chapter

This chapter introduces you to Excel-erator. The chapter:

- Gives an overview of Excel-erator.
- Describes the features of Excel-erator.
- Describes standard product support features.
- Describes Excel-erator's TOOBJ() parameter.
- Describes Excel-erator's relationship to other products.
- Outlines future directions for the product.
- Describes conventions used in this manual.

Excel-erator Overview

Excel-erator is an IBM i based software utility that converts IBM i database files into spreadsheets. The resulting PC files are either placed into any directory in IBM i's Integrated File System or sent as an attachment to an email. With Excel-erator you can make IBM i data available to your users in the form best suited to them.

Excel-erator Feature

Excel-erator converts database files into spreadsheets. Excel-erator supports the following database files:

- Physical files
- Logical files with a single record format

There are two commands that provide the conversion:

- Copy To Excel (CPYTOEXCEL)
- Send File Excel (SNDFEXCEL)

The Copy To Excel (CPYTOEXCEL) command takes a database file and an Integrated File System object (PC file) name as input. The file's contents are converted into a spreadsheet. The converted file is then placed in the requested Integrated File System object (PC file).

The Send File Excel (SNDFEXCEL) command takes a database file and an email address as input. The file's contents are converted into a spreadsheet. The converted file is then emailed to the requested recipient using IBM i's built-in mail support. IBM i delivers the mail in the manner appropriate to the recipient's mail client. The spreadsheet arrives as a MIME attachment to an email message.

When sending the email, you have a wide variety of options to tailor the delivered message to your specific needs. Addressing includes multiple recipients, copy recipients and blind copy recipients. Additionally, you can include multiple Reply-To: addresses as well as specify the email address the message appears to come from. Delivery confirmation by read receipt can also be specified. Optionally, a digitally signature can be included with the email.

Both commands can generate spreadsheets in Excel format or Comma Separated Values format. Where the format allow, the commands support:

- Multiple database files per spreadsheet
- Data in any coded character set ID (CCSID)
- Field selection and ordering
- Addition of title lines
- Selecting column headings from the file's field names, aliases or column headings (or *NONE)

- Control over column heading format including alignment, borders background pattern, bolding, etc.
- Addition of print header and print footer
- Selection of font typeface
- Addition of comments to cells
- File sharing settings including password protection and encryption
- Control over the color palette included in the spreadsheet

Commands to help you trouble shoot and, optionally, automatically configure IBM i to send mail are also included with Excel-erator.

The conversion process is described in detail in Chapter 6 Conversion.

Standard Product Support Features

GUMBO products include a range of standard features that make them easy to use, easy to manage, and easy to live with:

- Extensive manual, both online as menu option 1 and in PDF
- Context sensitive help for every command and parameter.
- Menu that provides organized access to the product's features.
- Products are packaged as licensed programs and participates in the full range of support provided by IBM i Licensed program installation, PTF management, etc. are handled with the same commands used to manage IBM® software.
- Unlike IBM® Licensed Programs, our products are packaged to allow multiple releases to be installed at the same time, which facilitates new release testing.
- Product PTFs are available on the web at www.gumbo.com.
- Our products include a hot site friendly automatic authorization function that allows you to immediately move operations to any back up or fail over machine without contacting us for a license key or authorization code.
- We include a Check Excel-erator Authorization (CHKXLAUT) command that allows you to exercise the product's authorization algorithm and insure there are no authorization "surprises".
- An installation verification option is available on the menu. You can easily verify that the product is correctly installed.
- All (applicable) objects in our products are digitally signed allowing you to verify their integrity. Modifications that could jeopardize the security of your system are easily detected with IBM i's Check Object Integrity (CHKOBJITG) command.
- Our products are upward compatible with future releases of IBM i. You can install a new releases of IBM i without installing a new release from us.
- Our products are compatible with all IBM i security levels. We use only published interfaces.

Excel-erator's TOOBJ() Parameter

The key to generating PC files when using Excel-erator's Copy To Excel (CPYTOEXCEL) command is the TOOBJ() parameter. The parameter specifies the name of the file in terms of IBM i's Integrated File System.

An Object (PC file) is a path that specifies the name and location of the file in terms of IBM i's Integrated File System.

Depending on the Integrated File System path specified, you can place the generated file in any file system known to IBM i including writing directly to Windows systems on the network, another System i or NFS server. Run the Work with Object Links (WRKLNK) command to view the available directories and file systems.

As an example, the generated file can be placed in a directory in IBM i's Open Systems file system (QOpenSys). To create file "ABC.TXT" in directory "MYDIRECTORY" in IBM i's QOpenSys, use the following TOOBJ() parameter:

```
TOOBJ ( ' /QOpenSys/MYDIRECTORY/ABC.TXT ' )
```

The path you specify must follow the naming conventions of the file system involved. For example, QOpenSys supports case-sensitive names and each component of the path can be up to 255 characters long. For complete details on file system name restrictions see the *Integrated File System* topic in the IBM i Information Center at <http://publib.boulder.ibm.com/series/>.

For additional information, see the *Accessing Files In The Integrated File System* section of this manual.

Note: We recommend that you not use the /QDLS file system, which is accessed using the WRKFLR command, unless you have a specific requirement for its features.

Excel-erator provides several special values that can be used to construct dynamic object (PC file) names. When the special values are found, the associated data is blank trimmed and substituted into the path specified when it is processed. If the data associated with a special value is blank, "BLANK" is substituted. If the data associated with a special value contains characters not allowed in an object name, question marks (?) for example, the name will be invalid and the command will fail. The special values must be delimited by an underscore ('_') a period ('.') a slash ('/' or '\') or another special value (which starts with '*').

The transform related special values are:

*TRNEXT	Transform dependent file extension CHAR(3) or CHAR(4). <ul style="list-style-type: none"> • XLS for *BIFF8 or *BIFF4. • csv for *CSVUTF8, *CSVUTF8M or *CSVRFC. • xml for *XMLSS. • xlsx for *OOXML.
----------------	--

The member related special values are:

*FILE	File name CHAR(10).
*FILELIB	Library containing the file CHAR(10).
*MBR	Member name CHAR(10).
*TEXT	Member Text 'description' CHAR(50).
*MBRCDAT	Date the member was created CHAR(7) CYYMMDD.
*MBRCCYY	CYY portion of *MBRCDAT CHAR(3).
*MBRCYY	YY portion of *MBRCDAT CHAR(2).
*MBRCMM	MM portion of *MBRCDAT CHAR(2).
*MBRCDD	DD portion of *MBRCDAT CHAR(2).
*MBRCTIM	Time the member was created CHAR(6) HHMMSS.
*MBRGDAT	Date the member was changed CHAR(7) CYYMMDD.
*MBRGYY	CYY portion of *MBRGDAT CHAR(3).
*MBRGYY	YY portion of *MBRGDAT CHAR(2).
*MBRGMM	MM portion of *MBRGDAT CHAR(2).
*MBRGDD	DD portion of *MBRGDAT CHAR(2).
*MBRGTIM	Time the member was changed CHAR(6) HHMMSS.

Product Positioning

Gumbo Software, Inc. has several IBM i based products:

Number	Licensed Program
2A55RM1	Report Manager - Automates report distribution, bursting and spooled file management
2A55SM1	SpoolMail - Converts IBM i spooled files into industry standard file formats and sends the resulting PC files to any email recipient
2A55SAM	Spool-a-Matic - Converts IBM i spooled files into industry standard file formats and places the resulting PC files in the Integrated File System
2A55XL1	Excel-erator - Converts database files into spreadsheets placing the resulting PC files in the Integrated File System or sends the resulting PC files to any email recipient
2A55DCR	Dicer - Merges/sorts/splits/duplicates spooled files
2A55RDA	Report Designer - Edits DDS, RPG and ILE/RPG print specifications
2A55SM2	Gumbo Mail - Sends email from your applications

There is some overlap between and unique function within the products. Choose the product or combination of products that provide the function you need:

Function	Product						
	RM1	SML	SAM	XL1	DCR	RDA	SM2
Primary input to product	SPL	SPL	SPL	DBF	SPL	SRC	IFS
Primary output from product	SPL	EML	IFS	I/E	SPL	SRC	EML
Monitor output queues for work	YES	YES	YES	—	—	—	—
Spooled file distribution	YES	—	—	—	—	—	—
Burst (split) spooled files	YES	YES	YES	—	YES	—	—
Merge/sort/duplicate spooled files	YES	—	—	—	YES	—	—
Convert spool to TXT PC file	YES	YES	YES	—	—	—	—
Convert spool to PDF/RTF/etc. PC file	—	YES	YES	—	—	—	—
Convert DB file to spreadsheet	—	—	—	YES	—	—	—
Email PC file as attachment	YES	YES	—	YES	—	—	YES
Write PC file to Integrated File System	YES	—	YES	YES	—	—	—
Set up IBM i SMTP & mail router	YES	YES	—	YES	—	—	YES
Edit DDS, RPG, ILE/RPG source code	—	—	—	—	—	YES	—
Where: DBF = Database file EML = Email IFS = PC file in the Integrated File System I/E = Both IFS and EML SPL = Spooled file SRC = Source code							

Future Directions

Future releases of Excel-erator will include enhanced functionality based on customer feedback. Additionally, enhancements are often added to a current release by Program Temporary Fix (PTF).

Candidate enhancements include:

- Support for conversion to OpenDocument Format (ODF) as described in *ISO/IEC 26300:2006 Open Document Format for Office Applications (OpenDocument) v1.0*.
- Support for conversion to Office Open XML (OOXML) as described in *ISO/IEC 29500:2008*.

Contact **GUMBO** to suggest additional enhancements.

Manual Conventions

A note on conventions used in this manual. In several places, instructions for entering commands are given. When the command is intended to be run from a PC command prompt, it is flagged by `[pc]`. When the command is intended to be run from an IBM i command line, it is flagged by `[i]`, or is not flagged at all. `[Enter]` denotes the enter key.

Chapter 2 Installation

What's In This Chapter

This chapter describes

- How to install Excel-erator.
- How to verify that Excel-erator is installed correctly.
- How to include the XLERATOR library in a job's library list.
- How to determine release dependencies.
- How to test a new release while leaving the old in production.
- How to remove Excel-erator from the system.
- How to find additional installation information.
- How to contact technical support.
- Hot site installation.
- Permanent Authorization Codes.

Installing Excel-erator

Follow these instructions to install Excel-erator V1R8M0 on your System i:

Prepare

If you are upgrading a previous release (if Excel-erator is currently installed on your System i) perform these steps before installing the software:

1. Read the Enhancement Summary to determine if any changes affect your installation.
2. Insure that the product is not in use, as the installation process must clear the product's library. This will fail if objects such as menus are in use. If the installation fails, the previous release will be restored.

Install

Note: If you have downloaded this software from the web, instructions specific to installing from the download can be found in the file "readme.htm" which was included.

1. Sign on to the system as the security officer (QSECOFR).
2. Verify that your machine is at IBM i V6R1M0 or later by running:

```
DSPDTAARA DTAARA (QGPL/QSS1MRI)
```

Note: If you are running a version of IBM i earlier than V6R1M0 you cannot install Excel-erator V1R8M0 on your machine. You must install an earlier version of Excel-erator or upgrade the operating system.

3. Verify that user domain objects are allowed in the libraries XLERATOR and QSRV, by running:

```
WRKSYSVAL SYSVAL (QALWUSRDMN)
```

Take option 5 to display the value. If the value is not *ALL, use option 2 to add libraries XLERATOR and QSRV to the list of libraries where user domain objects are allowed.

Note: QSRV is required to correctly process PTFs when they are loaded and applied.

4. Insure that IBM i will be able to verify the signatures that we apply to our product's objects by installing our Signing Certificate and Root CA Certificate using Digital Certificate Manager. Alternately, insure that signature verification will not prevent the restore operation by running:

```
WRKSYSVAL SYSVAL(QVIFYOBJRST)
```

Take option 5 to display the value. If the value is 3 or higher, use option 2 to temporarily change the value to 1.

5. Mount the distribution media in the appropriate device.
6. Submit the Restore Licensed Program (RSTLICPGM) command to batch:

```
RSTLICPGM LICPGM(2A55XL1) DEV(device-name) LNG(2924)
```

Note: "device-name" is the device the media was mounted on and is usually OPT01.

Note: During the restore operation, the system operator message queue may receive inquiry message CPA3DE4 "Directory not registered. (C G)". Unless you are using a directory naming convention similar to ours (that is the directory specified in the CPA3DE4's second level text is unrelated to our software), you can safely respond with a "G" to reestablish the relationship between the directory and the product. Typically, the message will occur three times.

Finish

When the RSTLICPGM command completes, library XLERATOR and directory '/Gumbo/ProdData/2A55XL1' contain the new software. To complete the installation:

1. If you have an Authorization letter with your permanent authorization code, enter it now.

Note: Excel-erator automatically grants 30 days usage for new installs or 90 days usage for release upgrades.

2. Determine which PTFs were included on the media by entering the following command:

```
DSPPTF LICPGM(2A55XL1)
```

3. Visit www.gumbo.com to determine if newer PTFs are available. If so, download and install them. The bottom of our PTF web page also includes a listing of any IBM PTFs that affect the product.

Note: **GUMBO** recommends downloading the current cumulative PTF package from www.gumbo.com after installing the software.

4. You can access the Excel-erator menu by entering the following command:

```
GO MENU (XLERATOR/XLERATOR)
```

Verifying Excel-erator Installation

You can verify that Excel-erator has been correctly installed by running the Check Product Option (CHKPRDOPT) command:

```
CHKPRDOPT PRDID(2A55XL1) RLS(V1R8M0) CHKSIG(*NONE)
```

Note: If you have installed our digital certificates, specify CHKSIG(*ALL) instead of CHKSIG(*NONE) and digital signatures will be checked.

If the message 'No errors detected by CHKPRDOPT.' is displayed on the bottom of your display when the command finishes, Excel-erator is installed correctly.

If the message is not displayed, check your job log messages or see the Recovery Procedures in the *Software Installation Problems* section of the *Trouble-Shooting* chapter of this manual.

Library List Considerations

Library XLERATOR must be in the library list of jobs using Excel-erator commands, or the commands must be qualified with library XLERATOR. Depending on your installation and intended use, you can choose to:

- Add library XLERATOR to the system library list. This insures every job in the system has access to Excel-erator commands. However, this introduces problems with installing new releases and is not recommended.
- Add library XLERATOR to the initial library list parameter of job descriptions controlling jobs that will use Excel-erator commands. (recommended)
- Run an ADDLIBLE XLERATOR command in individual threads requiring Excel-erator commands.
- Qualify the command names on each use:

```
XLERATOR/CHGXL1DFT
```

Library XLERATOR will be temporarily added to the product portion of the current thread's library list.

Determine the best method for your installation and perform any changes required.

Release Considerations

Excel-erator operates under IBM i V6R1M0 or higher. Releases occur on a different schedule than IBM releases. Once Excel-erator is installed, the following considerations apply:

- A new release of IBM i may be installed without installing a new release of Excel-erator.

Excel-erator uses only published or IBM sanctioned interfaces and is upward compatible with all releases of IBM i. The Excel-erator authorization code does not change.

- A new release of Excel-erator may be installed without installing a new release of IBM i.

Any change in the requirements for operating system release level will be noted in the documentation accompanying the Excel-erator release. The new authorization code must be entered.

- A new release of Excel-erator may be installed over any prior release of Excel-erator.

You can skip "missed" releases.

- More than one release of Excel-erator may be installed on a system at one time.

By restoring Excel-erator to a library other than XLERATOR, a new release can be installed for testing while the old release remains in production. Any release-to-release considerations that may apply will be noted in the documentation accompanying the new release. Additional operational considerations may apply. For more information on renaming a library during licensed program installation, see the Restore Licensed Program (RSTLICPGM) command and the New Release Testing section of this chapter.

- When a new release of Excel-erator is installed in the same library as an old release the following processing is performed in order to preserve data and Excel-erator authorization information:
 1. The Excel-erator library is saved to QGPL/XL1VxRyMz. Where VxRyMz is the old release.
 2. Product objects that contain default settings and operational information are copied to library QTEMP.
 3. The Excel-erator library is cleared.
 4. Excel-erator is restored.
 5. Default settings and operational information are copied back to the product objects.
 6. All objects duplicated to QTEMP are deleted.
 7. Save file QGPL/XL1VxRyMz is deleted.

Note: **GUMBO** recommends making a backup of the old release before installing a new release of Excel-erator.

New Release Testing

Unlike IBM licensed programs, **GUMBO** licensed programs are packaged in a way that allows multiple release to be installed on your System i at the same time. This feature allows you to test a new release while the old release remains in production.

The key to new release testing are the LIB() and CODHOMEDIR() parameters of IBM i's Restore License Program (RSTLICPGM) command which allow you to restore the product to a library name and directory different from those used during packaging.

To test a new release, follow this procedure:

1. Review the Enhancement Summary for any release-to-release considerations that could affect your installation.
2. Install the new release in library XL1V1R8M0 and directory '/Gumbo/ProdData/2A55XL1V1R8M0':

```
RSTLICPGM LICPGM(2A55XL1) DEV(device-name) LNG(2924)
          LIB(XL1V1R8M0) REPLACERLS(*NO)
          CODHOMEDIR('/Gumbo/ProdData/2A55XL1V1R8M0')
```

where device-name is the device the media was mounted on.

3. Perform your new release testing.
4. When testing is complete, you must delete the new release.

```
DLTLICPGM LICPGM(2A55XL1) RLS(V1R8M0) OPTION(*ALL)
```

Note: Do not delete nor rename libraries and directories to move the new release into production. Doing so will corrupt the license program information kept internally by IBM i. If this has already occurred, see the Software Installation Problems section of the *Trouble-Shooting* chapter of this manual.

5. Follow the installation instructions to place the new release into production.

Deleting Excel-erator

Follow these instructions to remove Excel-erator from your System i:

1. Sign on to the system as the security officer (QSECOFR).
2. Delete the Excel-erator library by using the Delete Licensed Program (DLTLICPGM) command:

```
DLTLICPGM LICPGM(2A55XL1) OPTION(*ALL)
```

These instructions delete an otherwise healthy installation of Excel-erator. If the installation has been damaged, follow the instructions for Installation Fails in the *Software Installation Problems* section of the *Trouble-Shooting* chapter of this manual.

Additional Installation Information

Additional detailed installation information and instructions can be found in *IBM i and related software > PDF file... > Installing, upgrading, or deleting IBM i and related software SC41-5120* topic in the IBM i Information Center at <http://publib.boulder.ibm.com/series/>.

Technical Support

If you encounter a problem with Excel-erator, you should:

- Review the information in the Trouble Shooting chapter for a description of and solution to common problems.
- Load and apply the current cumulative PTF package for the software. You can obtain the current package by visiting the web site listed below.

If the problem remains unresolved, contact:

GUMBO

Software, Inc.

809 W Howe St
Seattle, WA 98119
United States of America
Phone: 206-284-5078
Email: support@gumbo.com
Web: www.gumbo.com

Hot Site Installation

In the event of a catastrophic system failure, an otherwise properly licensed and authorized copy of our product may be copied to a back up or fail over machine. The product's authorization algorithm will detect that the software is operating on a machine serial number different than the licensed and authorized serial number and automatically create and install a 30-day temporary authorization code for the back up or fail over machine. You do not need to contact Gumbo Software, Inc. in the event of an emergency.

An otherwise properly licensed and authorized copy of this product may be transferred to a back up or fail over machine for the purpose of testing your emergency recovery procedures and the product's automatic temporary authorization function.

The correct sequence of steps is as follows:

1. Install the software and enter the permanent authorization code on your production machine.
2. Save the software from your production machine using the Save Licensed Program (SAVLICPGM) command. This creates an authorized copy, save it with your back ups.
3. When restoring to the back up or fail over machine you must first insure that any previous copies have been deleted. To delete a previous copy use the Delete Licensed Program (DLTLICPGM) command.
4. Restore the authorized copy to the back up or fail over machine using the Restore License Program (RSTLICPGM) command.
5. Confirm that the authorized copy was correctly restored by running the Check Product Option (CHKPRDOPT) command.

6. The first time the software is used on the back up or fail over machine the product's authorization algorithm will create and install a temporary authorization code running for 30 days. This allows you install the authorized copy in advance of a disaster.

Permanent Authorization Codes

When you purchase a product from us, or when we send you a new release of a product, you receive a permanent authorization code. Here we describe how to determine the information you must give us in order to receive a permanent authorization code and how to determine if the permanent authorization code you have received is correct for your installation.

The overwhelming majority of licenses purchased from us are **System Wide Licenses**. The other possibility, a **Partition Only License**, is described at the end of this section. For a System Wide License, permanent authorization codes are specific to a **Serial Number**, a **Processor Group**, and our product's **Release**. For a Partition Only License, permanent authorization codes are specific to a **Serial Number**, a **Partition ID Number**, the partition's **Maximum Processor Capacity**, and our product's **Release**.

In all cases, our permanent authorization codes are specific to a release of our product. The release of IBM i never makes a difference. To determine the release of our product installed on your System i, run:

```
DSPPTF LICPGM(2A55XL1)
```

Where the possible LICPGM numbers are:

Number	Licensed Program
2A55RM1	Report Manager - Automates report distribution, bursting and spooled file management
2A55SM1	SpoolMail - Converts IBM i spooled files into industry standard file formats and sends the resulting PC files to any email recipient
2A55SAM	Spool-a-Matic - Converts IBM i spooled files into industry standard file formats and places the resulting PC files in the Integrated File System
2A55XL1	Excel-erator - Converts database files into spreadsheets placing the resulting PC files in the Integrated File System or sends the resulting PC files to any email recipient
2A55DCR	Dicer - Merges/sorts/splits/duplicates spooled files
2A55RDA	Report Designer - Edits DDS, RPG and ILE/RPG print specifications
2A55SM2	Gumbo Mail - Sends email from your applications

The 5th line of the panel shows the release you are running. It is V1R8M0 in this example.

```

Display PTF Status
System: GUMBO4
Product ID . . . . . : 2A55XL1
IPL source . . . . . : ##MACH#A
Release . . . . . : V1R8M0

Type options, press Enter.
 5=Display PTF details  6=Print cover letter  8=Display cover letter

   PTF                               IPL
Opt ID      Status                    Action

(No PTFs found.)

Bottom
F3=Exit  F11=Display alternate view  F17=Position to  F12=Cancel

```

Note: It is possible that more than one release of a product is installed. To check, press `[Enter]`. If you are returned to the command line, only one release is installed.

All of our permanent authorization codes are serial number dependent. For a System Wide License they are also Processor Group dependent. To determine your system's serial number and processor group, run:

WRKLICINF

Lines 3 and 4 of the resulting panel show the serial number and processor group of your system.

```
Work with License Information                                GUMBO4
                                                           04/06/10 18:08:32
System serial number . . . . . : 1234567
Processor group . . . . . : P10

Type options, press Enter.
 1=Add license key  2=Change  5=Display detail  6=Print detail
 8=Work with license users ...

License
Opt Product  Term  Feature Description
---
5761SS1 V6R1M0 5050  IBM i
5761SS1 V6      5051  IBM i
5761SS1 V6R1M0 5103  Media and Storage Extensions
5761SS1 V6R1M0 5112  PSF 1-45 IPM Printer Support
5761SS1 V6R1M0 5113  PSF 1-100 IPM Printer Support
5761SS1 V6R1M0 5114  PSF Any Speed Printer Support
5761SS1 V6R1M0 5116  HA Switchable Resources
More...

Parameters or command
===>
F3=Exit          F5=Refresh  F11=Display Usage Information  F12=Cancel
F17=Position to F23=More options
(C) COPYRIGHT IBM CORP. 1980, 2007.
```

For a Partition Only License, permanent authorization codes depend on the Partition ID Number and maximum processor capacity. To determine the number and processor capacity of partitions on your system:

1. Start system service tools by running:

STRSST

2. After entering a Service tools user ID and Service tools password, select the option to Work with system partitions.
3. Select the option to Display partition information.
4. Select the option to Display partition processing configuration.
5. Note the Partition ID Number and Total Processor Maximum.

```

Display Partition Processing Configuration
System: GUMBO4
Number of system processors . . . . . : 2
Number of available system processors . . . . . : 0
Size of system main storage (MB) . . . . . : 4096
Size of available system main storage (MB) . . . . . : 0
Interactive feature available . . . . . : 0 %

Partition -----Total Processors-----
Identifier Name Current / Pending Minimum / Maximum
0 PRIMARY 1 / 1 1 / 1
1 SECONDARY 1 / 1 1 / 1

F3=Exit F5=Refresh F6=Print F10=Main storage
F11=Display allocated I/O resources F12=Cancel

```

Note: A Partition only license is not valid for a machine with only one partition.

Note: Our product's algorithm checks the authorization against the Total Processors Current value. If the maximum configured is larger than the license, the algorithm will grant usage as long as the current configured is within the license's limit, and will issue a warning.

Chapter 3 Menu

What's In This Chapter

This chapter describes how to access the Excel-erator menu, and reviews the functions that can be performed from the menu.

Accessing The Menu

The Excel-erator commands and functions that you will use most often are collected on a menu named XLERATOR. To access this menu use the Go To Menu (GO) command:

```
GO MENU (XLERATOR/XLERATOR)
```

Library XLERATOR is added to the product portion of the current thread's library list while the menu is displayed.

Menu Options

```
XLERATOR                Excel-erator                System:  XL1

Select one of the following:

    1. Online Manual

Excel-erator
    2. Copy To Excel                CPYTOEXCEL
    3. Send File Excel              SNDFEXCEL
    4. Verify the product is installed correctly  CHKPRDOPT

Other Options
    60. Mail Verification And Set Up  MAILSETUP
    61. Display Current PTF Status    DSPPTF
    62. Change Excel-erator Authorization  CHGXL1AUT
    63. Search Help Index            STRSCHIDX
    64. Change Excel-erator Default    CHGXL1DFT
    65. Check Excel-erator Authorization  CHKXL1AUT

Selection or command
===>

F3=Exit  F4=Prompt  F9=Retrieve  F12=Cancel
© Copyright Gumbo Software, Inc. 2001, 2011. All Rights Reserved.
```

The Excel-erator (XLERATOR) menu options are summarized below:

Note: See the detailed descriptions in later chapters for a complete explanation of each option.

Option 1. Online Manual

The online manual allows you to view the contents of the Excel-erator Manual from a work station.

Option 2. Copy To Excel

The Copy To Excel (CPYTOEXCEL) command converts one or more IBM i database files into an Excel spreadsheet which is stored in IBM i's Integrated File System.

Option 3. Send File Excel

The Send File Excel (SNDFEXCEL) command converts one or more IBM i database files into Excel spreadsheets which are then sent as an email to recipients.

Option 4. Verify the product is installed correctly CHKPRDOPT

Installation verification checks to make sure that Excel-erator has been correctly installed by running IBM i's Check Product Option (CHKPRDOPT) command.

Option 60. Mail Verification And Set Up Menu

The Mail Verification And Set Up menu provides commands to help you set up mail on your system and verify that it is operating correctly.

Option 61. Display Current PTF Status

Displays the Excel-erator PTFs that have been applied to the software.

Option 62. Change Excel-erator Authorization

The Change Excel-erator Authorization (CHGXL1AUT) command changes the authorization code for Excel-erator. The command is used to extend a demonstration period or to permanently authorize Excel-erator for a system or a partition.

Option 63. Search Help Index

Search help index allows you to access the Excel-erator help index and search for specific information.

Option 64. Change Excel-erator Default

The Change Excel-erator Default (CHGXL1DFT) command changes values used by Excel-erator to control processing and other activities.

Option 65. Check Excel-erator Authorization

The Check Excel-erator Authorization (CHKXL1AUT) command executes Excel-erator's authorization verification function. This allows you to determine whether and how the product is authorized for use.

Chapter 4 Set Up

What's In This Chapter

This chapter provides information on setting up your System i to send email created by Excel-erator. If you do not intend to use Excel-erator to create email, you can skip this chapter entirely. The chapter describes:

- How to select a quick start mail set up procedure.
- Quick start mail set up - Mail Router.
- Quick start mail set up - Direct Delivery.
- How to use the Verify/Set Up Local SMTP (VFYLOCAL) command.
- How to use the Verify/Set Up Mail Router (VFYROUTER) command.
- Manual mail set up steps you may need to perform.
- Additional mail set up resources.

Selecting The Quick Start Mail Set Up Procedure

Excel-erator creates email by constructing a MIME formatted message and passing it to IBM i for processing and delivery. If your System i is already configured for email delivery, no additional set up is needed and you can skip this chapter. If Excel-erator is the first application on the System i to generate email for delivery, there are IBM i configuration changes you must perform. Excel-erator includes a Mail Verification And Set Up menu (GO XLERATOR/MAILSETUP) that provides tools to help you make them.

However, the scope of this chapter is limited. If any of the following apply to your installation, proceed directly to the Additional Mail Set Up Resources section for references to help in configuring IBM i:

- Domino for IBM i is installed on the system.
- Multiple TCP/IP interfaces (other than *LOOPBACK) are configured.
- Multiple email domains require support.

There are two quick start mail set up procedures for configuring IBM i mail services described in this chapter. The procedures are:

- Quick start mail set up - Mail Router
- Quick start mail set up - Direct Delivery.

You only perform, at most, one of these. To select the correct procedure consider the following simplified configurations:

Figure: Mail Configurations

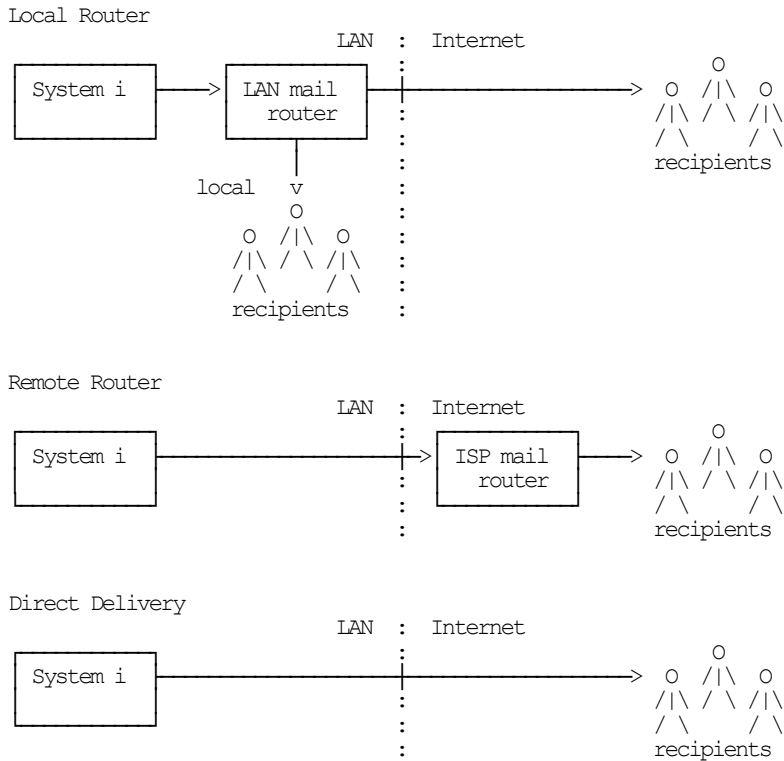

For most customers the System i is attached to a local area network that also has a mail server attached to it. Typically, the mail server runs on a PC with Exchange, Notes, Domino, GroupWise or similar mail application installed. Also, typically, this mail server should be responsible for delivering mail, and will server as the mail router for the System i. If this is you situation, proceed to the Quick Start Mail Set Up - Mail Router section.

For some customers, the mail server belonging to their internet service provider (ISP) is used to deliver email. If the ISP's mail server DOES NOT require SMTP authentication, proceed to the Quick Start Mail Set Up - Mail Router section.

If you do not have a mail server capable of serving as a mail router, or if your ISP's mail server requires SMTP authentication in order to relay email, you must configure your System i to deliver email directly. Proceed to the Quick Start Mail Set Up - Direct Delivery section.

Quick Start Mail Set Up - Mail Router

To configure your System i to use a mail server as its mail router follow these steps. If any of the steps fail, move on to the detailed sections of this chapter.

1. Install Excel-erator on your System i (see the Installation chapter for details).
2. Display the main menu (GO XLERATOR/XLERATOR).
3. Run the option to verify that Excel-erator is installed correctly.
4. Display the Mail Verification And Set Up menu.
5. Run option 12 to set up the System i.
6. Determine the name and IP address of the mail router.
7. Run option 14 to set up the mail router specifying its name and IP.
8. Press F12 to return to the main menu.
9. Send a test to yourself using your "real" email address.
10. Check your email.

If after a reasonable time no email arrives, perform the following additional steps.

1. Add your "real" email address to your directory entry by running (this example uses "real" email address "billg@acme.com" and the directory entry "MYUSER MYSYSTEM"):

```
CHGDIRE USRID (MYUSER MYSYSTEM)
        MSFSRVLVL (*SYSMS)  PREFADR (*SMTP)
        USRDFNFLD ((SMTPAUSRID SMTP 'billg')
                  (SMTPDMN SMTP 'acme.com'))
```

Note: If you are still signed on as QSECOFR, start a second session and sign on with your regular user profile to perform the send.

2. Display the Mail Verification And Set Up menu.
3. Run option 61 to restart/purge local mail on your System i.

Note: If your System i is currently being used to generate email from another application, make sure the Clear SMTP during restart (SMTPPURGE) and Clear MSF during restart (MSFPURGE) parameters specify *NO to prevent email from being deleted.

4. Send a test to yourself taking by taking the default *CURRENT.
5. Check your email.

If after a reasonable time no email arrives, move on to the detailed sections of this chapter. For additional information, see the *Trouble-Shooting* chapter of this manual.

Quick Start Mail Set Up - Direct Delivery

If your installation does not include a mail server or if you cannot use your ISP's mail server because it requires SMTP Authentication which is not support by IBM i, you can configure your System i to directly deliver email to the world at large using the following steps. If any of the steps fail, move on to the detailed sections of this chapter.

1. Install Excel-erator on your System i (see the Installation chapter for details).
2. Display the main menu (GO XLERATOR/XLERATOR).
3. Run the option to verify that Excel-erator is installed correctly.
4. Display the Mail Verification And Set Up menu.
5. Run option 12 to set up the System i.
6. Configure IBM i access to DNS (see Manual Mail Set Up Steps).
7. Remove previously configured mail router (see Manual Mail Set Up Steps).
8. Update the public DNS records for your domain (see Manual Mail Set Up Steps).
9. Press F12 to return to the main menu.
10. Send a test to yourself using your "real" email address.
11. Check your email.

If after a reasonable time no email arrives, perform the following additional steps.

1. Add your "real" email address to your directory entry by running (this example uses "real" email address "billg@acme.com" and the directory entry "MYUSER MYSYSTEM"):

```
CHGDIRE USRID (MYUSER MYSYSTEM)
        MSFSRVLVL (*SYSMS)  PREFADR (*SMTP)
        USRDFNFLD ((SMTPAUSRID SMTP 'billg')
                  (SMTPDMN SMTP 'acme.com'))
```

Note: If you are still signed on as QSECOFR, start a second session and sign on with your regular user profile to perform the send.

2. Display the Mail Verification And Set Up menu.
3. Run option 61 to restart/purge local mail on your System i.

Note: If your System i is currently being used to generate email from another application, make sure the Clear SMTP during restart (SMTPPURGE) and Clear MSF during restart (MSFPURGE) parameters specify *NO to prevent email from being deleted.

4. Send a test to yourself taking by taking the default *CURRENT.
5. Check your email.

If after a reasonable time no email arrives, move on to the detailed sections of this chapter. For additional information, see the *Trouble-Shooting* chapter of this manual.

Using The SMTP Set Up Command

The Verify/Set Up Local SMTP (VFYLOCAL) command performs automatic verification and set up of SMTP on your System i. The command accepts a single parameter that determines if changes are made to IBM i. To verify the System i without making any changes select option 11 on the Mail Verification And Set Up menu or run the following command:

```
VFYLOCAL SETUP (*NO)
```

To make changes to your System i select option 12 on the Mail Verification And Set Up menu or run the following command:

```
VFYLOCAL SETUP (*YES)
```

In both cases SMTP verification is performed. Only if SETUP(*YES) is specified does the command try to perform set up functions. You must be authorized to perform all of the verification and set up functions or the command fails. You can insure that you are authorized to perform all functions by signing on as QSECOFR.

Note: If you prefer to manually perform the functions of this program see the Appendix for a detailed description.

A log of activity is created during verification and set up. To view the log run DSPJOB, take option 4 and display the last spooled file.

If errors were encountered, detailed information can be found in your joblog. To view the information generated by VFYLOCAL, run the following command after the command has completed:

```
DSPJOBLOG
```

When the joblog is displayed, press F10 to display detailed messages and F18 to position to the end of the log.

The recommended procedure is to run verification first and review the results before running automatic set up.

Using The Mail Router Set Up Command

The Verify/Set Up Mail Router (VFYROUTER) command performs automatic verification and set up of a mail router for your System i. The command accepts three parameters that determine if changes are made to IBM i and the identity of the mail router. To verify the mail router without making any changes select option 13 on the Mail Verification And Set Up menu or run the following command (substitute the name and IP address of your external mail router for "host_name" and "ip"):

```
VFYROUTER RMTSYS(host_name) INTNETADR(ip) SETUP(*NO)
```

To make changes to your System i select option 14 on the Mail Verification And Set Up menu or run the following command (substitute the name and IP address of your external mail router for "host_name" and "ip"):

```
VFYROUTER RMTSYS(host_name) INTNETADR(ip) SETUP(*YES)
```

In both cases mail router verification is performed. Only if SETUP(*YES) is specified does the command try to perform set up functions. You must be authorized to perform all of the verification and set up functions or the command fails. You can insure that you are authorized to perform all functions by signing on as QSECOFR.

Note: If you prefer to manually perform the functions of this program see the Appendix for a detailed description.

A log of activity is created during verification and set up. To view the log run DSPJOB, take option 4 and display the last spooled file.

If errors were encountered, detailed information can be found in your joblog. To view the information generated by VFYROUTER, run the following command after the command has completed:

```
DSPJOBLOG
```

When the joblog is displayed, press F10 to display detailed messages and F18 to position to the end of the log.

The recommended procedure is to run verification first and review the results before running automatic set up.

Manual Mail Set Up Steps You May Need To Perform

Depending on your System i, network configuration and your intended usage, there are several manual mail set up steps you may need to perform in order to use SMTP. These are described here.

Installing TCP Connectivity Utilities

In order to send email from your System i, SMTP support must be installed. SMTP functions are delivered free of charge with IBM i as part of a separately installed licensed program product: 57xx-TC1 TCP/IP Connectivity Utilities. Detailed installation information and instructions can be found in *IBM i and related software > PDF file... > Installing, upgrading, or deleting IBM i and related software SC41-5120*.

Changing Local Host and Domain Names

SMTP uses your System i's local host and domain name to identify itself to remote SMTP hosts to which it is sending mail. To configure the names:

- Run the Configure TCP/IP (CFGTCP) command.
- Select option 12 (Change TCP/IP domain information).
- Enter a host and domain name for your System i.

As an example, we use **ofc.gumbo.com** as the domain name and the **mailout** as the host name on our machine. If your domain is widget.com you might use:

```
Change TCP/IP Domain (CHGTCPDMN)

Type choices, press Enter.

Host name . . . . . 'mailout'

Domain name . . . . . 'ofc.widget.com'

Domain search list . . . . . *DFT

Host name search priority . . . *LOCAL *REMOTE, *LOCAL, *SAME
Domain name server:
  Internet address . . . . . '192.0.2.1'
                          '192.0.2.2'

Bottom
F3=Exit  F4=Prompt  F5=Refresh  F10=Additional parameters  F12=Cancel
F13=How to use this display  F24=More keys
```

Creating a TCP Interface

A TCP interface establishes your System i identity (internet address) on a given line description. Typically, the line description for a local area network is used.

In order to add a TCP interface to a line description, you must determine the IP address and subnet mask to use. If you have a network administrator or other person responsible for assigning internet (IP) addresses, contact them. If you will connect your System i directly to the Internet, you must request that your internet service provider assign you an IP address or you must request that the Internet Corporation for Assigned Names and Numbers (ICANN) assign you a network number. If you will not connect your System i directly to the internet, and otherwise do not have an IP address for your system, you can use IP address "192.168.1.1" and Subnet Mask "255.255.255.0". This number is taken from the class B "192.168.0.0" network, which is reserved for internal networks as described in *RFC1597*. To add an interface after you have determined an IP address and subnet mask, run the following command:

```
ADDTCPIFC  INTNETADR(192.168.1.1) +
           LIND(line_description_name) +
           SUBNETMASK(255.255.255.0)
```

Substitute your values for the three parameters.

Adding Host Name To Host Table



In order to deliver email correctly IBM i's SMTP host name must be associated with an IP address of one its TCP interfaces. This can be accomplished through DNS or you can add a local host table entry. To add a host table entry for IP address "192.168.1.1" with host name mailout, run the following command:

```
ADDTCPHTE  INTNETADR('192.168.1.1') +
           HOSTNAME(('mailout'))
```

Substitute your values for the two parameters. If the IP address already exists in the host table, use Change TCP/IP Host Table Entry (CHGTCPHTE) command to add the additional host name to the IP address.

Configuring IBM i Access To DNS

When not using a mail router, System i must access domain name system (DNS) servers to determine how to deliver email for a recipient. Typically, IP addresses for DNS servers are supplied by your internet service provider (ISP) or network administrator. If neither is available, a reasonable guess as to the IPs to use can be retrieved from a PC attached to the local area network that contains the System i:

-  Choose Start > Programs > Accessories > Command Prompt
-  Run command:

```
ipconfig /all 
```

-  Note the IP addresses given for DNS Servers.

To configure System i to use DNS servers and confirm correct operation:

- From the IBM i command line, type CHGTCPDMN and press F4.
- Enter the DNS IP addresses in the Domain name server: Internet address (INTNETADR) parameter, press enter.

```

Change TCP/IP Domain (CHGTCPDMN)

Type choices, press Enter.

Host name . . . . . 'mailout'

Domain name . . . . . 'ofc.widget.com'

Domain search list . . . . . *DFT

Host name search priority . . . *LOCAL      *REMOTE, *LOCAL, *SAME
Domain name server:
  Internet address . . . . . '192.0.2.1'
                          '192.0.2.2'

Bottom
F3=Exit   F4=Prompt   F5=Refresh   F10=Additional parameters   F12=Cancel
F13=How to use this display   F24=More keys

```

This example uses the fictitious DNS IP addresses 192.0.2.1 and 192.0.2.2

- Run the command:

```
ping ibm.com
```

- If you do not get the message "Unknown host, ibm.com" DNS is working correctly.

Note: You may or may not get ping replies, but that is not important.

Removing Previously Configured Mail Router

IBM i will deliver email directly if a mail router is not configured. To check or remove the mail router specification, prompt the Change SMTP Attributes (CHGSMTPA) command, page down once and change the Mail router (MAILROUTER) parameter to *NONE:

```

Change SMTP Attributes (CHGSMTPA)

Type choices, press Enter.

User ID delimiter . . . . . '.'          *SAME, *DFT, 2, =, ., &, $...
Mail router . . . . . *NONE

Coded character set identifier   00819      1-65533, *SAME, *DFT
Outgoing EBCDIC/ASCII table:
  Outgoing EBCDIC/ASCII table . *CCSID   Name, *SAME, *CCSID, *DFT
  Library . . . . .           Name, *LIBL, *CURLIB
Incoming ASCII/EBCDIC table:
  Incoming ASCII/EBCDIC table . *CCSID   Name, *SAME, *CCSID, *DFT
  Library . . . . .           Name, *LIBL, *CURLIB
Firewall . . . . . *YES          *SAME, *YES, *NO
Journal . . . . . *YES          *SAME, *YES, *NO
Process all mail through MSF . . *YES          *SAME, *YES, *NO
Percent routing character . . . *YES          *SAME, *YES, *NO

More...
F3=Exit   F4=Prompt   F5=Refresh   F12=Cancel   F13=How to use this display
F24=More keys

```

Updating Public DNS Records

When directly delivering email to the world at large, System i contacts each recipient's mail server and introduces itself using the fully qualified SMTP host name configured using the Change TCP/IP Domain (CHGTCPDMN) command. In the example below, the machine introduces itself as mailout.ofc.widget.com.

```
Change TCP/IP Domain (CHGTCPDMN)

Type choices, press Enter.

Host name . . . . . 'mailout'

Domain name . . . . . 'ofc.widget.com'

Domain search list . . . . . *DFT

Host name search priority . . . *LOCAL *REMOTE, *LOCAL, *SAME
Domain name server:
  Internet address . . . . . '192.0.2.1'
                          '192.0.2.2'

Bottom
F3=Exit   F4=Prompt   F5=Refresh   F10=Additional parameters   F12=Cancel
F13=How to use this display   F24=More keys
```

When a recipient's mail server is contacted by IBM i, the mail server sees the traffic as coming from the publicly visible IP address of your connection. For example, the external IP address of your DSL modem. To determine the IP address seen externally, go to <http://network-tools.com>. The IP address shown in the search box is the external public IP address of your connection.

Increasingly, mail servers are confirming the identity of machines sending email by performing a DNS look up on the fully qualified host name sent during the introduction, mailout.ofc.widget.com in this example. If the IP address returned by DNS is not the same as the visible IP address the traffic is coming from, email is rejected or discarded as spam.

To insure that your System i passes this test, you must add, or have your domain registrar add, an address record for your System i's fully qualified SMTP host name to the DNS records for your domain. In this example:

```
mailout.ofc.widget.com. IN A nnn.nnn.nnn.nnn
```

Is added to the DNS records for the domain widget.com where nnn.nnn.nnn.nnn is the publicly visible IP address determined above. This usually requires contacting your domain name registrar or the ISP hosting your domain, and is not an IBM i setting.

Setting Up Local Users

A local user is someone who has a user profile (sign-on) on your System i. You should set up each local user who will be sending email to insure that the apparent "From:" address in the email will be correct and to insure that replies reach the sender. You do not need to set up local users who will not be sending mail. To configure hypothetical user JOE SALES (user profile JOES) as joe@acme.com, perform the following:

- If Joe already has a directory entry run:

```
CHGDIRE USRID(JOE SALES) MSFSRVLVL(*SYSMS)
        PREFADR(*SMTP)
        USRDFNFLD((SMTPAUSRID SMTP 'joe')
                  (SMTPDMN SMTP 'acme.com'))
```

- If Joe does not have a directory entry run:

```
ADDIRE USRID(JOE SALES) USRD('Sample entry')
      USER(JOES) SYSNAME(*LCL)
      MSFSRVLVL(*SYSMS) PREFADR(*SMTP)
      USRDFNFLD((SMTPAUSRID SMTP 'joe')
                (SMTPDMN SMTP 'acme.com'))
```

The user is now ready to send mail from your System i as joe@acme.com. For more details or information on setting up remote users, see the *Email Addresses* section of the *Implementation* chapter of this manual.

Changing The System Start Program

You may wish to check your system's start up program to insure that the required subsystems are started automatically when your System i IPLs. The following steps are recommended:

- Insure that the SMTP server starts automatically when the Start TCP/IP (STRTCP) command is run:

```
CHGSMTPA AUTOSTART(*YES)
```

- Insure that your system start up program starts TCP/IP by including the command:

```
STRTCP
```

- Insure that your system start up program starts the IBM i Mail Server by including the command:

```
STRMSF
```

Changing The Time Zone System Value

The time stamp placed in the email is based on the QTIMZON system value. Since most System i have the correct time, an incorrect time stamp usually indicates an incorrect time zone setting. For information on correctly setting the QTIMZON system value see the *System management > Time management* topic in the IBM i Information Center at <http://publib.boulder.ibm.com/series/>.

Note: QTIMZON also affects the timestamp applied to files in the Integrated File System (IFS).

Changing The SMTP Port Number

Some installations use an SMTP port number other than the well-known port 25. You can control the port number used by IBM i's SMTP stack by running the Configure TCP/IP (CFGTCP) command, selecting option 21. Configure related tables, then selecting option 1. Work with service table entries.

Additional Mail Set Up Resources

The information in this chapter was drawn and condensed from the IBM i Information Center. You can find additional detail and more comprehensive coverage of IBM i configuration by going to the *Networking > TCP/IP applications, protocols, and services > E-mail* topic in the IBM i Information Center at <http://publib.boulder.ibm.com/series/>.

For Domino on System i users, our software uses IBM i's SMTP services to deliver mail. Valuable information on setting up Domino's and IBM i's SMTP stack to coexist on the same System i can be found in the IBM Redbook *V5 TCP/IP Applications on the IBM eServer iSeries Server SG24-6321* available at <http://publib.boulder.ibm.com/series/>.

Chapter 5 Implementation

What's In This Chapter

This chapter describes how to implement Excel-erator in your environment. The chapter:

- Gives an overview of implementation choices.
- Describes changing programs to process files.
- Describes manually processing files.
- Describes accessing files in the Integrated File System.
- Shows how to create PDM options for Excel-erator's commands.
- Shows how to use OPNQRYF to select specific records.
- Describes using format codes in headers and footers.
- Describes email address details.
- Describes adding line breaks to the message.
- Describes digitally signing the message.
- Describes a CL coding tip.
- Describes changing command defaults.

Overview

Excel-erator converts database files into spreadsheets. There are two commands that provide the conversion:

- Copy To Excel (CPYTOEXCEL)
- Send File Excel (SNDFEXCEL)

To implement Excel-erator in your environment you have two basic choices:

1. Modify each program that creates files that will be converted to directly run the Copy To Excel (CPYTOEXCEL) or the Send File Excel (SNDFEXCEL) command.

Pros	The file is always processed as soon as it is created.
Cons	Programs must be modified and recompiled.

2. Manually run the Copy To Excel (CPYTOEXCEL) or the Send File Excel (SNDFEXCEL) command from a command line.

Pros	Good for casual or on demand use, no program changes required.
Cons	Requires manual operations and scheduling.

See the following sections for a detailed discussion of the choices.

Changing Programs

Excel-erator can be implemented by changing the programs that create files to convert or email them directly. A typical batch Control Language (CL) program that creates a file would contain the following CL sequence:

```
      .  
OVRDBF  FILE (INVENTORY)  TOFILE (INVLIB/INVENTORY)  
OVRDBF  FILE (INVSTATUS)  TOFILE (INVLIB/INVSTATUS)  
CLRPFM  FILE (INVLIB/INVSTATUS)  
CALL    PGM (INVLIB/INV320)  
      .  
      .
```

If program INV320 generates file INVSTATUS then the following changes will convert the file to the /Excel/INV320 directory and create a file with the date and time created as the name:

```
.
OVRDBF FILE(INVENTORY) TOFILE(INVLIB/INVENTORY)
OVRDBF FILE(INVSTATUS) TOFILE(INVLIB/INVSTATUS)
CLRPFM FILE(INVLIB/INVSTATUS)
CALL PGM(INVLIB/INV320)
CPYTOEXCEL FROMFILE(INVLIB/INVSTATUS) +
          TOOBJ('/Excel/INV320/InventoryStatus.xls')
.
```

The file is converted as soon as program INV320 has completed processing.

Alternately, the following changes will email the file to "billg@acme.com":

```
.
OVRDBF FILE(INVENTORY) TOFILE(INVLIB/INVENTORY)
OVRDBF FILE(INVSTATUS) TOFILE(INVLIB/INVSTATUS)
CLRPFM FILE(INVLIB/INVSTATUS)
CALL PGM(INVLIB/INV320)
SNDFEXCEL SDF((INVLIB/INVSTATUS)) +
          TO((billg@acme.com))
.
```

The file is emailed as soon as program INV320 has completed processing.

Manually Processing Files

Excel-erator can be implemented by assigning an operator the task of manually converting files. The Copy To Excel (CPYTOEXCEL) and Send File Excel (SNDFEXCEL) commands can be run from any command line or from the XLERATOR menu.

Accessing Files In The Integrated File System

Files are created in IBM i's Integrated File System (IFS). There are a variety of ways to access the contents of the IFS. The following common methods are described here:

- Accessing the file from a PC using IBM i's support for Windows Network Neighborhood (NetServer).
- Creating the file directly on a Windows machine using the IFS's QNTC file system.
- Transferring the file using FTP from a PC.
- Transferring the file using FTP from IBM i.
- Accessing the file from a PC using System i Access.

Complete, detailed, information can be found in the *Files and file systems > Integrated file system* topic in the IBM i Information Center at <http://publib.boulder.ibm.com/series/>.

Windows Network Neighborhood (NetServer)

IBM i Support for Windows Network Neighborhood (NetServer) allows a TCP/IP attached PC to access the Integrated File System using the file and print sharing built into Windows.

IBM i NetServer support does not require you to install any additional software on your personal computer. Similarly, NetServer does not require any software other than base IBM i V4R2M0 or later.

Follow these guidelines to get your System i set up to use NetServer. These instructions assume that you do not have access to System i Navigator. Whenever possible, you should use System i Navigator.

Note: You must have *IOSYSCFG special authority to change any part of NetServer configuration. In addition, you must have *SECADM special authority to change the NetServer guest user profile. These changes will take effect the next time NetServer is started.

1. Verify that TCP/IP support is configured on your System i.
2. Use the Work with Subsystems (WRKSBS) command to confirm that the QSERVER subsystem has started.
3. Verify that the NetServer name is unique on the network. To change the NetServer default server and domain name, use the following command:

```
CALL QZLSCHSN PARM(server_name domain_name
                    'text description or comment' X'00000000')
```

4. To change NetServer guest support, use the following command:

```
CALL QZLSCHSG PARM(guest_user_profile X'00000000')
```

Users who require the file and print-sharing capabilities of NetServer, but do not have an IBM i user profile need a guest user profile.

Note: The Guest User Profile should not have a password or any special authority.

5. Stop and start NetServer, using the following commands:

```
ENDTCPSVR SERVER (*NETSVR)
STRTCPSVR SERVER (*NETSVR)
```

The only directory that is automatically shared with the network is the \QCA400 directory. To create additional shares you must use System i Navigator and follow these steps:

1. Open a connection to your System i in System i Navigator.
2. Expand Network.
3. Expand Servers.
4. Click TCP/IP to retrieve a list of TCP/IP servers available.
5. Right-click NetServer and select Open.
6. Right-click Shared Objects and select New and then File.
7. Use the General Properties page to configure the new file share with a name, description, access, maximum number of users, and directory path name.

Note: The System i Navigator online help provides more details about NetServer file share properties.

Once a share has been created, map to it from your Windows PC by following these steps:

1. Right-click the Start button and choose Explore to open the Windows Explorer.
2. Open the Tools pull-down menu on the Windows Explorer and select Map network drive.
3. Select the letter of a free drive for the file share.
4. Enter the name of a NetServer file share. For example:

```
\\server_name\Sharename
```

Note: server_name is the system name of NetServer on System i, and Sharename is the name of the file share you want to use.

5. Click OK.

Alternately, you can use Network Neighborhood to access the share:

1. Open Windows Network Neighborhood.
2. Open QSYSTEM1 (Where QSYSTEM1 is the server name of NetServer on System i).
3. Select a file share.

QNTC File System

IBM i's QNTC file system allows the Integrated File System to write directly to Windows file shares (disk) as if it were local IBM i disk storage.

Path (file) names in QNTC consist of the file system name, the Windows server name, the sharename, the directory and sub-directory names, and the object name. Path (file) names have the following form:

```
/QNTC/Servername/Sharename/MyDirectory/MyFile.pdf
```

Use the Make Directory (MKDIR) command to add a Windows machine to QNTC. For example:

```
MKDIR DIR ('/QNTC/NTSRV1')
```

Adds the NTSRV1 server into the QNTC file system directory structure to enable access of files and directories on that server.

For additional detailed information, search IBM i Information Center for "QNTC".

FTP Using PC

FTP can be used from your PC to transfer the files to another system. In brief, the steps for retrieving the file /mydirectory/myfile.pdf from IFS to your PC are:

Note: `[PC]` denotes an operation performed on your PC. `[I]` denotes an operation performed on your System i. `[Enter]` denotes the enter key.

1. `[I]` Insure the IBM i FTP server is active by running this command from a command line:

```
STRTCPSVR SERVER(*FTP)
```

2. `[PC]` Choose Start > Programs > Accessories > Command Prompt to open a command prompt.
3. `[PC]` Open an FTP connection to the System i by running (use your system's name or IP address):

```
FTP system_name [Enter]
```

4. `[PC]` Enter a user name and password as prompted.
5. `[PC]` Change to binary (image) mode by running:

```
binary [Enter]
```

6. `[PC]` Switch to IBM i Integrated File System by running:

```
quote site namefmt 1 [Enter]
```

7. `[PC]` Retrieve the file by running:

```
get /mydirectory/myfile.pdf [Enter]
```

8. `[PC]` End FTP and command prompt by running:

```
quit [Enter]
exit [Enter]
```

For more details see *Networking* topic in the IBM i Information Center at <http://publib.boulder.ibm.com/series/>.

FTP Using IBM i

FTP can be used from IBM i to transfer the files to another system interactively or in batch. The interactive procedure is similar to the PC procedure, using "put" instead of "get". In brief, the steps for transferring the file /mydirectory/myfile.pdf from IFS to another system in batch are:

1. Create a source member containing the FTP commands that you would otherwise have to type at the terminal during an interactive session with the target server. By way of example, we use the following command sequence in member FTPCMDS in QGPL/QCLSRC.

```
user password
binary
namefmt 1
put /mydirectory/myfile.pdf
quit
```

2. Add the following statements to your program:

```
...
OVRDBF FILE (INPUT) TOFILE (QGPL/QCLSRC) MBR (FTPCMDS)
OVRDBF FILE (OUTPUT) TOFILE (QGPL/QCLSRC) MBR (FTPLOG)
FTP      RMTSYS (system_name)
...
```

For more details see *Networking > TCP/IP applications, protocols, and services > FTP* topic in the IBM i Information Center at <http://publib.boulder.ibm.com/series/>.

System i Access

System i Access includes software that connects to the System i and makes the integrated file system available to the PC. For more information see *System i Access* topic in the IBM i Information Center at <http://publib.boulder.ibm.com/series/>.

Creating PDM Options For Excel-erator

IBM's Program Development Manager (PDM) allows creation of user-defined options. For additional information, see *iSeries Programming Development Manager User's Guide SC09-2133*.

Creating A PDM Option For CPYTOEXCEL

The following steps will create the user-defined option "XL" which will submit a job to run the CPYTOEXCEL command from within PDM when "XL" is keyed next to a member name:

- Enter PDM by using the WRKMBRPDM command.
- Press F16 to work with user defined options.
- Press F6 to create a new user defined option.

```

Create User-Defined Option

Type changes, press Enter.

Option . . . . . XL Option to create

Command . . . . . /* Excel-erator CPYTOEXCEL Batch */
sbmjob job(&N) jobd(&J) cmd(xlerator/cpytoexcel fromfile(&l/&f)
toobj('/Excel/*filelib.*file.*mbr.xls') frommbr(&n) crtmdir(*yes))

F3=Exit      F4=Prompt      F12=Cancel

```

- Key the user defined option definition as shown above, and press Enter.
- Press F3 to exit the Work with User-Defined Options display. Now key XL in the option field for members to submit a batch conversion.

Creating A PDM Option For SNDFEXCEL

The following steps will create the user-defined option "XS" which will prompt the SNDFEXCEL command from within PDM when "XS" is keyed next to a file name:

- Enter PDM by using the WRKMBRPDM command.
- Press F16 to work with user defined options.
- Press F6 to create a new user defined option.

```

Create User-Defined Option

Type changes, press Enter.

Option . . . . . XS Option to create

Command . . . . . /* Excel-erator SNDFEXCEL */
?xlerator/sndfexcel sndf((&l/&n))

F3=Exit      F4=Prompt      F12=Cancel

```

- Key the user defined option definition as shown above, and press Enter.

- Press F3 to exit the Work with User-Defined Options display. Now key XS in the option field for a file to send it.

Selecting Records With OPNQRYF

In some cases, you may wish to create a spreadsheet containing a subset of records from the underlying database file. This can be accomplished using IBM i's Open Query File (OPNQRYF) command.

As an example, suppose you wish to select only the records for customer A1234 from the invoice records file QGPL/QINVREC, which contains the field CUST. To accomplish this with OPNQRYF, run the following commands:

```
OVRDBF      FILE(QINVREC) TOFILE(QGPL/QINVREC) OVRSCOPE(*JOB)
             SHARE(*YES)
OPNQRYF     FILE((QINVREC)) QRYSLT('CUST *EQ 'A1234''')
             OPNSCOPE(*JOB)
CPYTOEXCEL  FROMFILE(QINVREC)
             TOOBJ('/Excel/CustA1234InvoiceRecords.xls')
CLOF        OPNID(QINVREC)
DLTOVR      FILE(QINVREC) LVL(*JOB)
```

This procedure also works with the Send File Excel (SNDFEXCEL) command.

Using Format Codes In Headers And Footers

BIFF8 supports the use of format codes in the print headers and print footers that can be entered on the PRTHEADER() and PRTFOOTER() parameters. Some of the codes and their meaning are:

Format Code	Description
&L	Left-aligns the characters that follow.
&C	Centers the characters that follow.
&R	Right-aligns the characters that follow.
&B	Turns bold printing on or off.
&I	Turns italic printing on or off.
&D	Prints the current date.
&T	Prints the current time.
&F	Prints the name of the document.
&A	Prints the name of the worksheet.
&P	Prints the page number.
&&	Prints a single ampersand.
&N	Prints the total number of pages in the document.

As an example, to generate a spreadsheet with page numbers as the print footer, specify the following

```
CPYTOEXCEL ... PRTFOOTER('Page: &P of &N')
```

This also works with the Send File Excel (SNDFEXCEL) command.

Email Addresses

There are three choices for addressing mail created by Excel-erator, direct SMTP addressing, special values, and directory entries stored in the system distribution directory. With direct SMTP addressing, you enter the email address directly on the parameter, no additional address set up is required. Excel-erator supports the full range of email address formats, including route specification and *RFC3490 Internationalizing Domain Names in Applications (IDNA)*. Valid formats for email addresses include:

- 'mali@acme.com'
- '<mali@acme.com>'
- 'Mohammed Ali <mali@acme.com>'
- '"Mohammed Ali" <mali@acme.com>'

- 'Mohammed Ali (I am the Greatest) <mali@acme.com>'

In all of these examples the message is delivered to the mailbox mali@acme.com.

Address Resolution For Special Values

Excel-erator supplies several special values for specifying email addresses. For example, *CURRENT is the default value on the From (originator) Address parameter.

Excel-erator uses the following steps to resolve an email address for special values that imply an IBM i user profile.

- If the user profile implied by the special value is enrolled in the system distribution directory and the entry contains an email address the email address is used.
- If the user profile implied by the special value is enrolled in the system distribution directory and the entry does not contain an email address an IBM i style address is generated in the form: usrid?address@host.domain.
- If the user profile implied by the special value is not enrolled in the system distribution directory an email address is generated in the form: userprofile@host.domain

Note: In the above, host and domain are taken from the values entered on the CFGTCP option 12 panel.

Therefore, to have the correct email address resolved, you should add or update a system distribution directory entry for each user profile that will be referenced by the special values you will use. Usually this is every user profile that will send email.

Setting Up Directory Entry Email Addresses For Local Users

IBM i's system distribution directory can contain addressing information for users. Directory entries can be created for users who are local to the System i (have an IBM i user profile) and for users who are remote (do not have an IBM i user profile). Local users can receive their mail on the System i using IBM i's POP server or from a remote mail application such as Exchange. You should set up each local user who will be sending email to insure that the apparent "From:" address in the email will be correct and to insure that replies reach the sender. To add a directory entry for user profile **MYUSER**, run the following command: (for this example, assume the user's email address is billg@acme.com):

```
ADDIRE USRID(MYUSER MYSYSTEM) USRD('Sample entry')
      USER(MYUSER) SYSNAME(*LCL)
      MSFSRVLVL(*SYSMS) PREFADR(*SMTP)
      USRDFNFLD((SMTPAUSRID SMTP 'billg')
                (SMTPDMN SMTP 'acme.com'))
```

Note: If you are running Lotus Domino for IBM i, run:

```
ADDIRE USRID(MYUSER MYSYSTEM) USRD('Sample entry')
      USER(MYUSER) SYSNAME(*LCL)
      MSFSRVLVL(*DOMINO) PREFADR(*SMTP)
      USRDFNFLD((SMTPAUSRID SMTP 'billg')
                (SMTPDMN SMTP 'acme.com'))
```

To update an existing directory entry for user profile **MYUSER**, run the following command:

```
CHGDIRE USRID(MYUSER MYSYSTEM)
        MSFSRVLVL(*SYSMS) PREFADR(*SMTP)
        USRDFNFLD((SMTPAUSRID SMTP 'billg')
                  (SMTPDMN SMTP 'acme.com'))
```

Setting Up Directory Entry Email Addresses For Remote Users

You do not need to set up remote user in order to send them email, but it will enable you to use distribution lists. To add a directory entry for a remote user who will receive email mail from the System i, run the following command (for this example, assume the user's email address is johnp@acme.com):

```

ADDDIRE USRID(RMT1 EMAIL) USRD('Sample entry 2')
      USER(*NONE) SYSNAME(TCPIP)
      MSFSRVLVL(*SYSMS) PREFADR(*SMTP)
      USRDFNFLD((SMTPAUSRID SMTP 'johnp')
                (SMTPDMN SMTP 'acme.com'))

```

Note: The choice of USRID(RMT1 EMAIL) is arbitrary, select names that are convenient. The system name must be **TCPIP**.

To add a directory entry for a Domino user who does not have an IBM i user profile, run the following command (for this example, assume the user's email address is suej@acme.com):

```

ADDDIRE USRID(DOMINO EMAIL) USRD('Sample entry 3')
      USER(*NONE) SYSNAME(TCPIP)
      MSFSRVLVL(*DOMINO) PREFADR(*SMTP)
      USRDFNFLD((SMTPAUSRID SMTP 'suej')
                (SMTPDMN SMTP 'acme.com'))

```

Note: The choice of USRID(DOMINO EMAIL) is arbitrary, select names that are convenient. The system name must be **TCPIP**.

Using Distribution Lists

Once you have directory entries set up you can also set up distribution lists. These are lists of recipients (both local and remote) that can be maintained independently of the programs that use the lists. By sending to a distribution list, you send to each entry on the list.

Like directory entries, distribution list IDs have two parts. To make it convenient to manage the system, set up a naming convention for list IDs; for example, INV320 REPORT and INV330 REPORT could be list IDs for recipients of the INV320 and INV330 reports respectively. Such a convention allows lists to be easily associated with their use.

Suppose that the INV320 report should be sent to billg@acme.com and to johnp@acme.com. To create a distribution list to reflect this, run the following commands:

1. Create the distribution list:

```

CRTDSTL LSTID(INV320 REPORT)
      LSTD('INV320 report distribution')

```

2. Add 2 entries to the distribution list:

```

ADDSTLE LSTID(INV320 REPORT)
      USRID((MYUSER MYSYSTEM) (RMT1 EMAIL))

```

You are now ready to send to the two users with one command by specifying the **To (distribution list)** parameter:

```
(other command parameters) ... TOUSRID(INV320 REPORT)
```

Adding Line Breaks to the Message

The following CL program fragment shows how to create a message variable that contains a line break (carriage return/line feed pair):

```

...
DCL VAR(&MSG) TYPE(*CHAR) LEN(2048)
DCL VAR(&CRLF) TYPE(*CHAR) LEN(2) VALUE(X'0D25')
...
CHGVAR VAR(&MSG) +
      VALUE('First line.' *CAT &CRLF *CAT 'Second line.')
...

```

The resulting message is:

```
First line.  
Second line.
```

In Cobol, a similar result can be had using the hexadecimal literal X"0D25".

Digitally Signing The Message

Email produced by Excel-erator can be, optionally, digitally signed using S/MIME Signed Message format. S/MIME (Secure / Multipurpose Internet Mail Extensions) is a standard for public key encryption and signing of email encapsulated in MIME. A signed message is an ordinary message with a digital signature added by the sender. The signature has two purposes: it identifies the sender, and it verifies that the content of the message has not been altered since the message was sent.

You create digitally signed email by specifying an **Application ID** when the email is created. There are two ways to accomplish this: at the command level and at the system (or LPAR) level. The command level overrules the system level. For command level, specify an **Application ID** directly on the send command's new **Signing key** (SGNKEY) parameter. For the system level, specify an **Application ID** on the CHGXLDFT command's new **Signing key** (SGNKEY) parameter.

The shipped default values for the **Signing key** (SGNKEY) parameters are *DEFAULT and *NONE respectively.

Application ID refers to the name you have given to a digital certificate when placing it in the *OBJECTSIGNING Certificate Store using IBM i's Digital Certificate Manager (DCM). DCM is option 34 of IBM i. You can determine if DCM has been installed by running the Display Software Resources (DSPSFWRSC) command.

Complete information on setting up DCM, creating and storing certificates and adding **Application IDs**, can be found in the *Security > Digital Certificate Manager* topic in the IBM i Information Center at <http://publib.boulder.ibm.com/series/>.

CL Coding Tip

Many of our commands accept a variable number of values for a given parameter. For example, the Send Spool Mail (SNDSPLMAIL) command accepts up to 300 email addresses on the recipient parameter. When writing CL programs, the problem of how to code for a variable number of email addresses without coding the SNDSPLMAIL command multiple times (once for each address count) arises. The solution is a little known CL trick for coding "no value" in a variable. "No value" is represented in CL by '*N'. Consider the following program fragment:

```
PGM  
DCL      VAR (&ADD1) TYPE (*CHAR) LEN (128) VALUE ('*N')  
DCL      VAR (&ADD2) TYPE (*CHAR) LEN (128) VALUE ('*N')  
DCL      VAR (&ADD3) TYPE (*CHAR) LEN (128) VALUE ('*N')  
.  
CHGVAR   VAR (&ADD1) VALUE (NOBODY@GUMBO.COM)  
.  
SNDSPLMAIL FILE (QPDSPLIB) TRANSFORM (*TXT) +  
            TOSMTPNAME ((&ADD1) (&ADD2) (&ADD3))  
.  
ENDPGM
```

Since &ADD2 and &ADD3 contain '*N' they are treated as if they were not specified on the command and the email is sent to only one address.

Changing Command Defaults

As with any CL command, you can change the default values of the commands found in our products. You do this using the IBM i Change Command Default (CHGCMDDFLT) command.

But before you do, there are some gotchas (Slang term for "I got you": a trap) you should be aware of. You WILL lose the change each time a new release of the product is installed, and you COULD lose the change when PTFs are applied to the product. You must then reapply the default change.

As an example, to change the default transform on SpoolMail's SNDSPLMAIL command from *TXT to *PDF4, run the following:

```
CHGCMDDEF CMD(SNDSPLMAIL) NEWDEF('TRANSFORM(*PDF4)')
```

GUMBO recommends AGAINST changing command defaults, we know from the calls for support we receive that this regularly causes problems for customers.

Chapter 6 Conversion

What's In This Chapter

This chapter describes the file conversion available with Excel-erator. The chapter:

- Gives an overview of the available conversions.
- Describes ***BIFF8** conversion details and limitations.
- Describes ***BIFF4** conversion details and limitations.
- Describes ***CSVUTF8** conversion details and limitations.
- Describes ***CSVUTF8M** conversion details and limitations.
- Describes ***CSVRFC** conversion details and limitations.
- Describes ***XMLSS** conversion details and limitations.
- Describes ***OOXML** conversion details and limitations.

Overview

Excel-erator retrieves the requested database file from IBM i and converts the data into a PC file in spreadsheet format.

The transform parameter determines the type of conversion performed and therefore the format of the generated spreadsheet. The supported formats are:

Transform	Format Description
*BIFF8	Microsoft's Binary Interchange File Format Version 8, the format used by Excel version 8.0 (Excel 97/98), Excel 9.0 (Excel 2000/2001), Excel 10.0 (Excel XP/v.X) and Excel 11.0 (Excel 2003/2004).
*BIFF4	Microsoft's Binary Interchange File Format Version 4, the format used by Excel version 4.0 (Excel 4.0). Note: *BIFF4 is include for compatibility reasons and its use is not recommended in preference to *BIFF8
*CSVUTF8	Comma Separated Values (CSV) format. Data is converted to UTF-8. Trailing blanks are trimmed.
*CSVUTF8M	Comma Separated Values (CSV) format. Data is converted to UTF-8 and Byte Order Mark xEFBBBF is inserted at the start of the file. Trailing blanks are trimmed.
*CSVRFC	Comma Separated Values (CSV) format. Data is converted to US-ASCII in strict compliance with <i>RFC4180 Common Format and MIME Type for Comma-Separated Values (CSV) Files</i> . Trailing blanks are trimmed.
*XMLSS	Microsoft's Excel specific "XML Spreadsheet format" introduced with Excel 2002 and Excel 2003.
*OOXML	Office Open XML developed by Microsoft. Excel-erator implements the ISO/IEC 29500:2008 Strict specification, suitable for use with Excel 2010 and suitable for use with Excel 2007 if dates are not present in the spreadsheet. See http://en.wikipedia.org/wiki/Office_Open_XML for additional information.

For all transforms, each record in the database file creates a row in the spreadsheet, while each selected field in the record creates a cell in the row. Logical files are supported, but only if they have a single record format. Our calls to the underlying IBM i apis specify that overrides should be processed when retrieving file information and data.

Not all parameters are applicable to all transforms:

Figure: Parameter Applicability By Transform

Parameter	Transform							MsgId
	*	*	*	*	*	*	*	
	B	B	C	C	C	X	O	
	I	I	S	S	S	M	O	
	F	F	V	V	V	L	X	
	F	F	U	U	R	S	M	
	8	4	T	T	F	S	L	
			F	F	C			
			8	8				
			M					
COLHDG	YES	YES	YES	YES	YES	YES	YES	XL17006
SHEETNAME	YES	-	-	-	-	YES	YES	XL17004
SHEETTITLE	YES	-	-	-	-	YES	YES	XL17005
ADDWS	YES	-	-	-	-	YES	YES	XL17003
PRTHEADER	YES	YES	-	-	-	YES	YES	XL17007
PRTFOOTER	YES	YES	-	-	-	YES	YES	XL17008
FONT	YES	YES	-	-	-	YES	YES	XL17009
COMMENT	YES	YES	-	-	-	YES	YES	XL17010
TRGCCSID	-	YES	-	-	-	-	-	XL17011
SRCCSID	-	YES	-	-	-	-	-	XL17012
FILESHARE	YES	YES	-	-	-	-	-	XL17014
COLHDGFMT	YES	YES	-	-	-	YES	YES	XL17015
PALETTE	YES	YES	-	-	-	YES	YES	XL17016
CSVSEPCHR	-	-	YES	YES	-	-	-	SCV7001

The following sections describe the conversions in more detail.

*BIFF8 Conversion Details and Limitations

Details

The *BIFF8 conversion creates Microsoft Excel 2003/2004 spreadsheets. The first rows of the spreadsheet contain the title lines specified on the Sheet title (SHEETTITLE) parameter, followed by column headings specified on the Column headings (COLHDG) parameter, which serve as column headings for the cells in subsequent rows. The generated spreadsheet contains the fields selected from the input file's record format. Fields containing character data (types A, J, E, O, and G) are converted to BIFF8's internal encoding based on the field's coded character set identifier (CCSID).

Note: Values specified in the Target coded character set id (TRGCCSID), and Source coded character set id (SRCCSID) parameters are ignored.

The conversion of fields to cells depends on the field's data type:

Data Type	Processing
A (Character)	Convert to a text cell in BIFF8's internal format based on the CCSID of the field. Trailing blanks are trimmed.
P (Packed decimal)	Convert to a number cell.
S (Zoned decimal)	Convert to a number cell.
B (Binary)	Convert to a number cell.
F (Floating point)	Convert to a number cell.
H (Hexadecimal)	Copy to a text cell without conversion.
L (Date)	Convert to a date cell with *ISO formatting.
T (Time)	Convert to a time cell with *ISO formatting.
Z (Timestamp)	Convert to a date cell with *ISO formatting. The microseconds are omitted.
J (DBCS-Only)	Convert to a text cell in BIFF8's internal format based on the CCSID of the field. Trailing blanks are trimmed.
E (DBCS-Either)	Convert to a text cell in BIFF8's internal format based on the CCSID of the field. Trailing blanks are trimmed.
O (DBCS-Open)	Convert to a text cell in BIFF8's internal format based on the CCSID of the field. Trailing blanks are trimmed.
G (DBCS-Graphic)	Convert to a text cell in BIFF8's internal format based on the CCSID of the field. Trailing blanks are trimmed.
1 (BLOB)	Omit and issue a warning.

2 (CLOB)	Omit and issue a warning.
3 (DBCLOB)	Omit and issue a warning.
4 (Datalink)	Omit and issue a warning.

Limitations

Microsoft's BIFF8 spreadsheet format and Excel-erator impose certain limits on the conversion process. These are:

- A spreadsheet may have no more than 64 worksheets.
- When a database file has more than 65536 records it is split into multiple worksheets of 65536 rows each. This gives an effective limit of 2,097,152 records.
- A spreadsheet may have no more than 256 columns.
- All BIFF8 numbers are represented internally as long doubles, which can give slightly different decimal position results. That is, the IBM i value 123.456 might show up as 123.456001 when viewed in the cell.
- BIFF8's format strings do not support the features of IBM i's edit words. A trivial translation is performed.

*BIFF4 Conversion Details and Limitations

Details

The *BIFF4 conversion creates Microsoft Excel 4.0 spreadsheets. The first rows of the spreadsheet contain the title lines specified on the Sheet title (SHEETTITLE) parameter, followed by column headings specified on the Column headings (COLHDG) parameter, which serve as column headings for the cells in subsequent rows. The generated spreadsheet contains the fields selected from the input file's record format. These are converted from EBCDIC to ASCII based on the values specified in the command's Target coded character set id (TRGCCSID), and Source coded character set id (SRCCSID) parameters.

The conversion of fields to cells depends on the field's data type:

Data Type	Processing
A (Character)	Convert to a text cell based on the SRCCSID and TRGCCSID. The data is trimmed if it exceeds the Excel maximum of 255. Trailing blanks are trimmed.
P (Packed decimal)	Convert to a number cell.
S (Zoned decimal)	Convert to a number cell.
B (Binary)	Convert to a number cell.
F (Floating point)	Convert to a number cell.
H (Hexadecimal)	Copy to a text cell without conversion.
L (Date)	Convert to a date cell with *ISO formatting.
T (Time)	Convert to a time cell with *ISO formatting.
Z (Timestamp)	Convert to a date cell with *ISO formatting. The microseconds are omitted.
J (DBCS-Only)	Omit and issue a warning.
E (DBCS-Either)	Omit and issue a warning.
O (DBCS-Open)	Omit and issue a warning.
G (DBCS-Graphic)	Omit and issue a warning.
1 (BLOB)	Omit and issue a warning.
2 (CLOB)	Omit and issue a warning.
3 (DBCLOB)	Omit and issue a warning.
4 (Datalink)	Omit and issue a warning.

Limitations

Microsoft's BIFF4 spreadsheet format and Excel-erator impose certain limits on the conversion process. These are:

- Double byte character set data is not supported.
- A spreadsheet may have only one worksheet.
- A spreadsheet may have no more than 65536 rows.

- A spreadsheet may have no more than 256 columns.
- A character field may have a maximum length of 255.
- All BIFF4 numbers are represented internally as long doubles, which can give slightly different decimal position results. That is, the IBM i value 123.456 might show up as 123.456001 when viewed in the cell.
- BIFF4's format strings do not support the features of IBM i's edit words. A trivial translation is performed.

*CSVUTF8 Conversion Details and Limitations

Details

The *CSVUTF8 conversion creates Comma Separated Values spreadsheets in compliance with *RFC4180 Common Format and MIME Type for Comma-Separated Values (CSV) Files* with the exceptions noted below. The first rows of the spreadsheet can optionally contain column headings as specified on the Column headings (COLHDG) parameter. These serve as column headings for the cells in subsequent rows. The generated spreadsheet contains the fields selected from the input file's record format.

The exceptions are:

- While RFC4180 only allows US-ASCII, fields containing character data (types A, J, E, O, and G) are converted to UTF8 based on the field's coded character set identifier (CCSID). This insures that any and all character data can be included. If the character data happens to all be US-ASCII (all single byte UTF8), the resulting file is strictly compliant with RFC4180.
- While RFC4180 specifies a separator character of comma (','), alternate separator characters can be specified using the CSVSEPCHR() parameter.

Note: Values specified in the Target coded character set id (TRGCCSID), and Source coded character set id (SRCCSID) parameters are ignored.

The conversion of fields to values depends on the field's data type. In all cases, quoting rules are applied after conversion, as needed:

Data Type	Processing
A (Character)	Convert to UTF8 based on the CCSID of the field. Trailing blanks are trimmed. Fields with embedded separator characters are enclosed within double-quote characters. Fields with embedded double-quote characters are enclosed within double-quote characters, and each of the embedded double-quote characters is represented by a pair of double-quote characters. Fields with embedded line breaks are enclosed within double-quote characters.
P (Packed decimal)	Convert to a UTF8 character value with EDTCDE() or EDTWRD() applied if specified.
S (Zoned decimal)	Convert to a UTF8 character value with EDTCDE() or EDTWRD() applied if specified.
B (Binary)	Convert to a UTF8 character value with EDTCDE() or EDTWRD() applied if specified.
F (Floating point)	Convert to a UTF8 character value in external floating-point format.
H (Hexadecimal)	Copy without conversion.
L (Date)	Convert to a UTF8 character value based on the specified DATFMT() and DATSEP().
T (Time)	Convert to a UTF8 character value based on the specified TIMFMT() and TIMSEP().
Z (Timestamp)	Convert to a UTF8 character value.
J (DBCS-Only)	Converted to UTF8 based on the CCSID of the field. Trailing blanks are trimmed.
E (DBCS-Either)	Converted to UTF8 based on the CCSID of the field. Trailing blanks are trimmed.
O (DBCS-Open)	Converted to UTF8 based on the CCSID of the field. Trailing blanks are trimmed.
G (DBCS-Graphic)	Converted to UTF8 based on the CCSID of the field. Trailing blanks are trimmed.
1 (BLOB)	Omitted and a warning is issued.
2 (CLOB)	Omitted and a warning is issued.
3 (DBCLOB)	Omitted and a warning is issued.
4 (Datalink)	Omitted and a warning is issued.

Limitations

Comma Separated Value and Excel-erator impose certain limits on the conversion process. These are:

- A spreadsheet may have only one database member.
- Bolding requests are ignored.

*CSVUTF8M Conversion Details and Limitations

Details

The *CSVUTF8M conversion is identical to *CSVUTF8 in all respects except one. For *CSVUTF8M a byte order mark of xEFBBBF is placed at the beginning of the generated file.

Limitations

Same as *CSVUTF8 limitations listed above.

*CSVRFC Conversion Details and Limitations

Details

The *CSVRFC conversion is identical to *CSVUTF8 in all respect except one. For *CSVRFC if any data can not be converted to US-ASCII (CCSID=367), the conversion process fails and a spreadsheet is not generated.

Limitations

Same as *CSVUTF8 limitations listed above with two additions:

- All data must convert to US-ASCII (CCSID=367).
- The separator character must be *COMMA (',').

*XMLSS Conversion Details and Limitations

Details

The *XMLSS conversion creates Microsoft's Excel specific "XML Spreadsheet format" introduced with Excel 2002 and Excel 2003. The first rows of the spreadsheet contain the title lines specified on the Sheet title (SHEETTITLE) parameter, followed by column headings specified on the Column headings (COLHDG) parameter, which serve as column headings for the cells in subsequent rows. The generated spreadsheet contains the fields selected from the input file's record format. Fields containing character data (types A, J, E, O, and G) are converted to UTF8 based on the field's coded character set identifier (CCSID).

Note: Values specified in the Target coded character set id (TRGCCSID), and Source coded character set id (SRCCSID) parameters are ignored.

The conversion of fields to cells depends on the field's data type:

Data Type	Processing
A (Character)	Convert to a String cell in UTF8 based on the CCSID of the field. Trailing blanks are trimmed.
P (Packed decimal)	Convert to a Number cell.
S (Zoned decimal)	Convert to a Number cell.
B (Binary)	Convert to a Number cell.
F (Floating point)	Convert to a Number cell.
H (Hexadecimal)	Convert to a String cell as a character representation.
L (Date)	Convert to a DateTime cell.
T (Time)	Convert to a DateTime cell.
Z (Timestamp)	Convert to a DateTime cell. The microseconds are truncated to three positions.
J (DBCS-Only)	Convert to a String cell in UTF8 based on the CCSID of the field. Trailing blanks are trimmed.
E (DBCS-Either)	Convert to a String cell in UTF8 based on the CCSID of the field. Trailing blanks are trimmed.
O (DBCS-Open)	Convert to a String cell in UTF8 based on the CCSID of the field. Trailing blanks are trimmed.
G (DBCS-Graphic)	Convert to a String cell in UTF8 based on the CCSID of the field. Trailing blanks are trimmed.
1 (BLOB)	Omit and issue a warning.
2 (CLOB)	Omit and issue a warning.
3 (DBCLOB)	Omit and issue a warning.

4 (Datalink) Omit and issue a warning.

Limitations

Microsoft's XML Spreadsheet format and Excel-erator impose certain limits on the conversion process. These are:

- A spreadsheet may have no more than 64 worksheets.
- XML Spreadsheet format's format strings do not support the features of IBM i's edit words. A trivial translation is performed.

While XML Spreadsheet format does not impose limits on the number of rows or columns in a spreadsheet, various file viewers do, most prominently Excel. For example, Excel 2007 imposes a limit of 1,048,578 rows and 16,384 columns.

*OOXML Conversion Details and Limitations

Details

The *OOXML conversion creates Office Open XML developed by Microsoft. Excel-erator implements the ISO/IEC 29500:2008 Strict specification, suitable for use with Excel 2010 and suitable for use with Excel 2007 if dates are not present in the spreadsheet. See http://en.wikipedia.org/wiki/Office_Open_XML for additional information. The first rows of the spreadsheet contain the title lines specified on the Sheet title (SHEETTITLE) parameter, followed by column headings specified on the Column headings (COLHDG) parameter, which serve as column headings for the cells in subsequent rows. The generated spreadsheet contains the fields selected from the input file's record format. Fields containing character data (types A, J, E, O, and G) are converted to UTF8 based on the field's coded character set identifier (CCSID).

Note: Values specified in the Target coded character set id (TRGCCSID), and Source coded character set id (SRCCSID) parameters are ignored.

The conversion of fields to cells depends on the field's data type:

Data Type	Processing
A (Character)	Convert to a String cell in UTF8 based on the CCSID of the field. Trailing blanks are trimmed.
P (Packed decimal)	Convert to a Number cell.
S (Zoned decimal)	Convert to a Number cell.
B (Binary)	Convert to a Number cell.
F (Floating point)	Convert to a Number cell.
H (Hexadecimal)	Convert to a String cell as a character representation.
L (Date)	Convert to an ISO DateTime cell.
T (Time)	Convert to an ISO DateTime cell.
Z (Timestamp)	Convert to an ISO DateTime cell. The microseconds are truncated to three positions.
J (DBCS-Only)	Convert to a String cell in UTF8 based on the CCSID of the field. Trailing blanks are trimmed.
E (DBCS-Either)	Convert to a String cell in UTF8 based on the CCSID of the field. Trailing blanks are trimmed.
O (DBCS-Open)	Convert to a String cell in UTF8 based on the CCSID of the field. Trailing blanks are trimmed.
G (DBCS-Graphic)	Convert to a String cell in UTF8 based on the CCSID of the field. Trailing blanks are trimmed.
1 (BLOB)	Omit and issue a warning.
2 (CLOB)	Omit and issue a warning.
3 (DBCLOB)	Omit and issue a warning.
4 (Datalink)	Omit and issue a warning.

Limitations

Office Open XML format and Excel-erator impose certain limits on the conversion process. These are:

- A spreadsheet may have no more than 64 worksheets.
- Office Open XML does not support encryption.
- Office Open XML's format strings do not support the features of IBM i's edit words. A trivial translation is performed.

While Office Open XML format does not impose limits on the number of rows or columns in a spreadsheet, various file viewers do, most prominently Excel.

Chapter 7 Commands

What's In This Chapter

This chapter describes the control language (CL) commands supplied by Excel-erator. The commands are arranged in alphabetic order by command name (mnemonic). Each description includes environment and threadsafe classification, a brief general description, detailed parameter explanations, examples and message information. Additional explanatory material can be found in the *Programming > Control Language > CL Concepts > CL Commands > CL command information and documentation* topic in the IBM i Information Center at <http://publib.boulder.ibm.com/series/>.

Change Excel-erator Authorization (CHGXL1AUT)

Where allowed to run: All environments (*ALL)

Threadsafe: No

The Change Excel-erator Authorization (CHGXL1AUT) command changes the authorization code for Excel-erator. The command is used to extend a demonstration period or to permanently authorize Excel-erator for a system or a partition.

Parameters

Keyword	Description	Choices	Notes
AUTH	Authorization code	<i>Hexadecimal value</i>	Required, Positional 1
EXPDAT	Expiration date (CCYYMMDD)	<i>Character value, <u>*NONE</u></i>	Optional, Positional 2
LICTYP	License type	<i><u>*SYS</u>, *LPAR</i>	Optional, Positional 3
PRCMAX	Processor maximum capacity	<i>Decimal number</i>	Optional, Positional 4

Authorization code (AUTH)

Specifies the authorization code to use. The authorization code is 8 hex digits that may be entered in upper or lower case.

This is a required parameter.

hexadecimal-value Specify the case insensitive authorization code.

Expiration date (CCYYMMDD) (EXPDAT)

Specifies the date on which the authorization expires.

***NONE** The authorization is permanent.
date The date on which the authorization expires in CCYYMMDD format.

License type (LICTYP)

Specifies the type of license that is authorized.

***SYS** The authorization is for a system wide license, which enables any and all partitions on the system but is specific to the processor group.

Note: The authorization code must be entered in each partition.

***LPAR** The license is specific to one of the partitions on the system and specific to a number of processors within the partition. A partition license must be entered in the partition for which it is intended.

Processor maximum capacity (PRCMAX)

Specifies the maximum processor capacity for which the partition is licensed. The value is expressed in terms of processors where 1.00 is 100% of a processor's capacity or the same as 1 processor, .50 is 50% of a processor's capacity or .5 processors, 2.00 is 200% of a processor's capacity or 2 processors, etc.

decimal-number Specify the maximum processor capacity.

Examples

Example 1:

```
CHGXL1AUT AUTH(01234567)
```

This command changes the authorization code to a permanent system wide license code.

Example 2:

```
CHGXL1AUT AUTH(01234567) LICTYP(*LPAR) PRCMAX(1.3)
```

This command changes the authorization code to a permanent partition only license code for 1.3 processors in the current partition.

Change Excel-erator Default (CHGXL1DFT)

Where allowed to run: All environments (*ALL)

Threadsafe: No

The Change Excel-erator Default (CHGXL1DFT) command changes values used by Excel-erator to control processing and other activities.

Parameters

Keyword	Description	Choices	Notes
SGNKEY	Signing key	Single values: *SAME , *NONE Other values: <i>Element list</i>	Optional, Positional 1
	Element 1: Application ID	<i>Character value</i>	

Signing key (SGNKEY)

Specifies the default digital certificate used to sign email.

The signature included with the email allows the recipient to validate the identity of the sender and provides additional assurance that the email has not been tampered with after it is signed.

A certificate is referenced by specifying the name (Application ID) of an object signing application created using IBM i's Digital Certificate Manager.

*SAME	The value is not changed.
*NONE	No signing operation is performed.
<i>application-id</i>	Specify the application identifier to use in the signing operation.

Examples

Example 1:

```
CHGXL1DFT SGNKEY (*NONE)
```

This command removes the default digital certificate. By default, emails are not signed.

Example 2:

```
CHGXL1DFT SGNKEY (WIDGETEMAIL)
```

This command changes the application identifier used to locate a digital certificate used to sign email, by default.

Check Excel-erator Authorization (CHKXL1AUT)

Where allowed to run: All environments (*ALL)

Threadsafe: No

The Check Excel-erator Authorization (CHKXL1AUT) command executes Excel-erator's authorization verification function. This allows you to determine whether and how the product is authorized for use.

Parameters

Keyword	Description	Choices	Notes
MSGQ	Message queue	Single values: <u>*NONE</u> Other values: <i>Qualified object name</i>	Optional, Positional 1
	Qualifier 1: Message queue	<i>Name</i>	
	Qualifier 2: Library	<i>Name</i> , <u>*LIBL</u> , *CURLIB	

Message queue (MSGQ)

Specifies a message queue that should receive messages if the product is not permanently authorized.

Single values

*NONE Messages are not sent to an external message queue.

Qualifier 1: Message queue

name Specify the name message queue that receives messages.

Qualifier 2: Library

*LIBL All libraries in the thread's library list are searched.

*CURLIB Use the current library for the job. If no library is specified as the current library for the job, QGPL is used.

name Specify the name of the library.

Examples

Example 1:

```
CHKXL1AUT
```

This command executes Excel-erator's authorization verification function to determine whether and how the product is authorized for use.

Example 2:

```
CHKXL1AUT MSGQ(QSYSOPR)
```

This command executes Excel-erator's authorization verification function to determine whether and how the product is authorized for use. If the product is not permanently authorized for use, a failure message is sent to the system operator's message queue.

Copy To Excel (CPYTOEXCEL)

Where allowed to run: All environments (*ALL)
 Threadsafte: No

The Copy To Excel (CPYTOEXCEL) command converts one or more IBM i database files into an Excel spreadsheet which is stored in IBM i's Integrated File System.

Parameters

Keyword	Description	Choices	Notes
FROMFILE	From file	<i>Qualified object name</i>	Required,
	Qualifier 1: From file	<i>Name</i>	Positional 1
	Qualifier 2: Library	<i>Name, *LIBL, *CURLIB</i>	
TOOBJ	Object	<i>Character value, *FILE, *FILELIB, *TRNEXT, *MBR, *TEXT, *MBRCDAT, *MBRCCYY, *MBRCYY, *MBRCMM, *MBRCDD, *MBRCTIM, *MBRGDAT, *MBRGCYY, *MBRGYY, *MBRGMM, *MBRGDD, *MBRGTIM</i>	Required, Positional 2
FROMMBR	From member	<i>Name, *FIRST, *LAST</i>	Optional, Positional 3
COLHDG	Column headings	<i>*FLDNAM, *ALIAS, *COLHDG, *COLHD1, *NONE, *FLDNAMBLD, *ALIASBLD, *COLHDGBLD, *COLHD1BLD</i>	Optional, Positional 4
FIELD	Field	Single values: <i>*ALL</i> Other values (up to 256 repetitions): <i>Name</i>	Optional
TRANSFORM	Transform	<i>*BIFF8, *CSVUTF8, *CSVUTF8M, *CSVRFC, *BIFF4, *XMLSS, *OOXML</i>	Optional
SHEETNAME	Sheet name	<i>Character value, *FILE, *FILELIB, *MBR, *TEXT, *MBRCDAT, *MBRCCYY, *MBRCYY, *MBRCMM, *MBRCDD, *MBRCTIM, *MBRGDAT, *MBRGCYY, *MBRGYY, *MBRGMM, *MBRGDD, *MBRGTIM</i>	Optional
SHEETTITLE	Sheet title	Single values: <i>*NONE</i> Other values (up to 5 repetitions): <i>Character value</i>	Optional
ADDWS	Add worksheet	Single values: <i>*NONE</i> Other values (up to 31 repetitions): <i>Element list</i>	Optional
	Element 1: From file	<i>Qualified object name</i>	
	Qualifier 1: From file	<i>Name</i>	
	Qualifier 2: Library	<i>Name, *LIBL, *CURLIB</i>	
	Element 2: From member	<i>Name, *FIRST, *LAST</i>	
	Element 3: Field	Single values: <i>*ALL</i> Other values (up to 256 repetitions): <i>Name</i>	
Element 4: Sheet name	<i>Character value, *FILE, *FILELIB, *MBR, *TEXT, *MBRCDAT, *MBRCCYY, *MBRCYY, *MBRCMM, *MBRCDD, *MBRCTIM, *MBRGDAT, *MBRGCYY, *MBRGYY, *MBRGMM, *MBRGDD, *MBRGTIM</i>		
Element 5: Sheet title	Single values: <i>*NONE</i> Other values (up to 5 repetitions): <i>Character value</i>		
PRTHEADER	Print header	<i>Character value, *RCDTEXT, *MBRTEXT, *FILTEXT, *NONE</i>	Optional
PRTFOOTER	Print footer	<i>Character value, *RCDTEXT, *MBRTEXT, *FILTEXT, *NONE</i>	Optional
FONT	Font typeface	<i>Character value, *ARIAL, *COURIER</i>	Optional
COMMENT	Cell comments	Single values: <i>*NONE</i> Other values (up to 32 repetitions): <i>Element list</i>	Optional
	Element 1: Column	1-256, <u>A</u> , B, C, D, E, F, G, H, I, J, K, L, M, N, O, P, Q, R, S, T, U, V, W, X, Y, Z, AA, AB, AC, AD, AE, AF, AG, AH, AI, AJ, AK, AL, AM, AN, AO, AP, AQ, AR, AS, AT, AU, AV, AW, AX, AY, AZ, BA, BB, BC, BD, BE, BF, BG, BH, BI, BJ, BK, BL, BM, BN, BO, BP, BQ, BR, BS, BT, BU, BV, BW, BX, BY, BZ, CA, CB, CC, CD, CE, CF, CG, CH, CI, CJ, CK, CL, CM, CN, CO, CP, CQ, CR, CS, CT, CU, CV, CW, CX, CY, CZ, DA, DB, DC, DD, DE, DF, DG, DH, DI, DJ, DK, DL, DM, DN, DO, DP, DQ, DR, DS, DT, DU, DV, DW, DX, DY, DZ, EA, EB, EC, ED, EE, EF, EG, EH, EI, EJ, EK, EL, EM, EN, EO, EP, EQ, ER, ES, ET, EU, EV, EW, EX, EY, EZ, FA, FB, FC, FD, FE, FF, FG, FH, FI, FJ, FK, FL, FM, FN, FO, FP, FQ, FR, FS, FT, FU, FV, FW, FX, FY, FZ, GA, GB, GC, GD, GE, GF, GG, GH, GI, GJ, GK, GL, GM, GN, GO, GP, GQ, GR, GS, GT, GU, GV, GW, GX, GY, GZ, HA, HB, HC, HD, HE, HF, HG, HH, HI, HJ, HK, HL, HM, HN, HO, HP, HQ, HR, HS, HT, HU, HV, HW, HX, HY, HZ, IA, IB, IC, ID, IE, IF, IG, IH, II, IJ, IK, IL, IM, IN, IO, IP, IQ, IR, IS, IT, IU, IV	

	Element 2: Row	1-65536, 1	
	Element 3: Text	<i>Character value</i>	
TRCCSID	Target coded character set id	1-65533, 1252	Optional
SRCCSID	Source coded character set id	1-65533, *KBDTYPE , *SYSVAL, *JOBDFI	Optional
REPLACE	Replace PC file data	*NO, *YES , Y, N	Optional
DTAAUT	Data authorities	*ALL , *NONE, *RWX, *RX, *RW, *WX, *R, *W, *X, *EXCLUDE, *INHERIT	Optional
CRDIR	Create directories	*NO , *YES, Y, N	Optional
OWNER	Owner	<i>Name</i> , *CURUSRPRF	Optional
OBJATR	Object attribute	Single values: *NONE Other values (up to 2 repetitions): <i>Element list</i>	Optional
	Element 1: Attribute	*DISKSTGOPT	
	Element 2: Value	*NORMAL , *MINIMIZE, *DYNAMIC	
FILESHARE	File sharing	<i>Element list</i>	Optional
	Element 1: Password to open	<i>Character value</i>	
	Element 2: Password to modify	<i>Character value</i>	
	Element 3: Read-only recommended	*YES, *NO , Y, N	
COLHDGFM	Column heading format	Single values: *DEFAULT Other values: <i>Element list</i>	Optional
	Element 1: Alignment-Horizontal	*GENERAL , *TYPE, *LEFT, *CENTER, *RIGHT, *FILL, *JUSTIFY, *CENTERSEL, 0, 1, 2, 3, 4, 5, 6, 8	
	Element 2: Border-Top line style	*NONE , *THIN, *MEDIUM, *DASHED, *DOTTED, *THICK, *DOUBLE, *HAIR, 0, 1, 2, 3, 4, 5, 6, 7	
	Element 3: Border-Left line style	*NONE , *THIN, *MEDIUM, *DASHED, *DOTTED, *THICK, *DOUBLE, *HAIR, 0, 1, 2, 3, 4, 5, 6, 7	
	Element 4: Border-Bottom line style	*NONE , *THIN, *MEDIUM, *DASHED, *DOTTED, *THICK, *DOUBLE, *HAIR, 0, 1, 2, 3, 4, 5, 6, 7	
	Element 5: Border-Right line style	*NONE , *THIN, *MEDIUM, *DASHED, *DOTTED, *THICK, *DOUBLE, *HAIR, 0, 1, 2, 3, 4, 5, 6, 7	
	Element 6: Border-Top line color	*SYSTEM , *BLACK, *WHITE, *RED, *BRIGHTGREEN, *BLUE, *YELLOW, *PINK, *TURQUOISE, *DARKRED, *GREEN, *DARKBLUE, *DARKYELLOW, *VIOLET, *TEAL, *GRAY25, *GRAY50, *COLOR1, *COLOR2, *COLOR3, *COLOR4, *COLOR5, *COLOR6, *COLOR7, *COLOR8, *COLOR9, *COLOR10, *COLOR11, *COLOR12, *COLOR13, *COLOR14, *COLOR15, *COLOR16, 32767, 8, 9, 10, 11, 13, 14, 15, 16, 17, 18, 19, 20, 21, 22, 23	
	Element 7: Border-Left line color	*SYSTEM , *BLACK, *WHITE, *RED, *BRIGHTGREEN, *BLUE, *YELLOW, *PINK, *TURQUOISE, *DARKRED, *GREEN, *DARKBLUE, *DARKYELLOW, *VIOLET, *TEAL, *GRAY25, *GRAY50, *COLOR1, *COLOR2, *COLOR3, *COLOR4, *COLOR5, *COLOR6, *COLOR7, *COLOR8, *COLOR9, *COLOR10, *COLOR11, *COLOR12, *COLOR13, *COLOR14, *COLOR15, *COLOR16, 32767, 8, 9, 10, 11, 13, 14, 15, 16, 17, 18, 19, 20, 21, 22, 23	
	Element 8: Border-Bottom line color	*SYSTEM , *BLACK, *WHITE, *RED, *BRIGHTGREEN, *BLUE, *YELLOW, *PINK, *TURQUOISE, *DARKRED, *GREEN, *DARKBLUE, *DARKYELLOW, *VIOLET, *TEAL, *GRAY25, *GRAY50, *COLOR1, *COLOR2, *COLOR3, *COLOR4, *COLOR5, *COLOR6, *COLOR7, *COLOR8, *COLOR9, *COLOR10, *COLOR11, *COLOR12, *COLOR13, *COLOR14, *COLOR15, *COLOR16, 32767, 8, 9, 10, 11, 13, 14, 15, 16, 17, 18, 19, 20, 21, 22, 23	
	Element 9: Border-Right line color	*SYSTEM , *BLACK, *WHITE, *RED, *BRIGHTGREEN, *BLUE, *YELLOW, *PINK, *TURQUOISE, *DARKRED, *GREEN, *DARKBLUE, *DARKYELLOW, *VIOLET, *TEAL, *GRAY25, *GRAY50, *COLOR1, *COLOR2, *COLOR3, *COLOR4, *COLOR5, *COLOR6, *COLOR7, *COLOR8, *COLOR9, *COLOR10, *COLOR11, *COLOR12, *COLOR13, *COLOR14, *COLOR15, *COLOR16, 32767, 8, 9, 10, 11, 13, 14, 15, 16, 17, 18, 19, 20, 21, 22, 23	
	Element 10: Patterns-Type	*NONE , *SOLID, *GRAY75, *GRAY50, *GRAY25, *GRAY12, *GRAY6, *STRIPEH50, *STRIPEH25, *STRIPEV50, *STRIPEV25, *STRIPED50, *STRIPED25, *STRIPEDR50, *STRIPEDR25, *HATCHD75, *HATCHD50, *HATCHD38, *HATCHH38, 0, 1, 2, 3, 4, 5, 6, 7, 8, 9, 10, 11, 12, 13, 14, 15, 16, 17, 18	
	Element 11: Patterns-Foreground color	*AUTOMATIC , *BLACK, *WHITE, *RED, *BRIGHTGREEN, *BLUE, *YELLOW, *PINK, *TURQUOISE, *DARKRED, *GREEN, *DARKBLUE, *DARKYELLOW, *VIOLET, *TEAL, *GRAY25, *GRAY50, *COLOR1, *COLOR2, *COLOR3, *COLOR4, *COLOR5, *COLOR6, *COLOR7, *COLOR8, *COLOR9, *COLOR10, *COLOR11, *COLOR12, *COLOR13, *COLOR14, *COLOR15, *COLOR16, 24, 8, 9, 10, 11, 13, 14, 15, 16, 17, 18, 19, 20, 21, 22, 23	

	Element 12: Patterns-Background color	*AUTOMATIC , *BLACK, *WHITE, *RED, *BRIGHTGREEN, *BLUE, *YELLOW, *PINK, *TURQUOISE, *DARKRED, *GREEN, *DARKBLUE, *DARKYELLOW, *VIOLET, *TEAL, *GRAY25, *GRAY50, *COLOR1, *COLOR2, *COLOR3, *COLOR4, *COLOR5, *COLOR6, *COLOR7, *COLOR8, *COLOR9, *COLOR10, *COLOR11, *COLOR12, *COLOR13, *COLOR14, *COLOR15, *COLOR16, 25, 8, 9, 10, 11, 13, 14, 15, 16, 17, 18, 19, 20, 21, 22, 23	
	Element 13: Protection-Locked	*YES , *NO, 0, 1	
PALETTE	Color palette	Values (up to 16 repetitions): <i>Element list</i>	Optional
	Element 1: Color to replace	*BLACK, *WHITE, *RED, *BRIGHTGREEN, *BLUE, *YELLOW, *PINK, *TURQUOISE, *DARKRED, *GREEN, *DARKBLUE, *DARKYELLOW, *VIOLET, *TEAL, *GRAY25, *GRAY50	
	Element 2: Red component	0-255	
	Element 3: Green component	0-255	
	Element 4: Blue component	0-255	
CSVSEPCHR	CSV separator character	<i>Character value</i> , *COMMA , *PERIOD, *PIPE, *SEMICOLON, *SLASH, *TAB	Optional

From file (FROMFILE)

Specifies the database file to copy. CHAR(10), CHAR(10).

This is a required parameter.

Qualifier 1: From file

name Specify the name of the file.

Qualifier 2: Library

***LIBL** All libraries in the thread's library list are searched.

***CURLIB** Use the current library for the job. If no library is specified as the current library for the job, QGPL is used.

name Specify the name of the library.

Object (TOOBJ)

Specifies the path name of the object (PC file) to create.

For more information on specifying path names, see *Programming > Control language > CL concepts > IBM i objects > Object naming rules* topic in the IBM i Information Center at <http://publib.boulder.ibm.com/series/>.
CHAR(5000)

This is a required parameter.

path-name Specify up to 5000 characters of path name. For example, to create a file with name **abc.txt** in a directory with name **mydirectory**, specify **'/mydirectory/abc.txt'**

Excel-erator provides several special values that can be used to construct dynamic object (PC file) names. When the special values are found, the associated data is blank trimmed and substituted into the path specified when it is processed. If the data associated with a special value is blank, "BLANK" is substituted. If the data associated with a special value contains characters not allowed in an object name, question marks (?) for example, the name will be invalid and the command will fail. The special values must be delimited by an underscore ('_') a period (.) a slash (/) or a backslash (\) or another special value (which starts with '*').

The transform related special values are:

***TRNEXT** Transform dependent file extension CHAR(3) or CHAR(4).

- XLS for *BIFF8 or *BIFF4.
- csv for *CSVUTF8, *CSVUTF8M or *CSVRFC.
- xml for *XMLSS.
- xlsx for *OOXML.

The member related special values are:

*FILE	File name CHAR(10).
*FILELIB	Library containing the file CHAR(10).
*MBR	Member name CHAR(10).
*TEXT	Member Text 'description' CHAR(50).
*MBRCDAT	Date the member was created CHAR(7) CYYMMDD.
*MBRCCYY	CYY portion of *MBRCDAT CHAR(3).
*MBRCYY	YY portion of *MBRCDAT CHAR(2).
*MBRCMM	MM portion of *MBRCDAT CHAR(2).
*MBRCDD	DD portion of *MBRCDAT CHAR(2).
*MBRCTIM	Time the member was created CHAR(6) HHMMSS.
*MBRGDAT	Date the member was changed CHAR(7) CYYMMDD.
*MBRGCYY	CYY portion of *MBRGDAT CHAR(3).
*MBRGYY	YY portion of *MBRGDAT CHAR(2).
*MBRGMM	MM portion of *MBRGDAT CHAR(2).
*MBRGDD	DD portion of *MBRGDAT CHAR(2).
*MBRGTIM	Time the member was changed CHAR(6) HHMMSS.

From member (FROMBR)

Specifies the name of the member to copy. CHAR(10).

*FIRST	The first member in the database from-file is processed.
*LAST	The last member in the database from-file is processed.
<i>name</i>	Specify the name of the database from-file member to process.

Column headings (COLHDG)

Specifies the column headings generated. CHAR(10)

*FLDNAM	The file's field names are used as column headings.
*ALIAS	The file's field aliases are used as column headings.
*COLHDG	The file's field column headings are used as column headings.
*COLHD1	The file's field column headings are used as column headings. A heading with multiple lines is text wrapped into a single cell.
*NONE	No column headings are included.
*FLDNAMBLD	The file's field names are used as column headings. The column headings are bold.
*ALIASBLD	The file's field aliases are used as column headings. The column headings are bold.
*COLHDGBLD	The file's field column headings are used as column headings. The column headings are bold.
*COLHD1BLD	The file's field column headings are used as column headings. A heading with multiple lines is text wrapped into a single cell. The column headings are bold.

Field (FIELD)

Specifies the list of fields to include in the spreadsheet. CHAR(10)

Single values

*ALL	All fields in the database file are included in the spreadsheet in the order they appear in the file.
-------------	---

Other values (up to 256 repetitions)

<i>name</i>	Specify the list of field names to be included in the spreadsheet. The fields appear in the spreadsheet in the order specified, duplicates are allowed.
--------------------	---

Transform (TRANSFORM)

Specifies the target format to which the data is transformed. CHAR(10).

*BIFF8	Microsoft's Binary Interchange File Format Version 8, the format used by Excel version 8.0 (Excel 97/98), Excel
---------------	---

	9.0 (Excel 2000/2001), Excel 10.0 (Excel XP/v.X) and Excel 11.0 (Excel 2003/2004).
*BIFF4	Microsoft's Binary Interchange File Format Version 4, the format used by Excel version 4.0 (Excel 4.0). Note: *BIFF4 is include for compatibility reasons and its use is not recommended in preference to *BIFF8
*CSVUTF8	Comma Separated Values (CSV) format. Data is converted to UTF-8. Trailing blanks are trimmed.
*CSVUTF8M	Comma Separated Values (CSV) format. Data is converted to UTF-8 and Byte Order Mark xEFBBBF is inserted at the start of the file. Trailing blanks are trimmed.
*CSVRFC	Comma Separated Values (CSV) format. Data is converted to US-ASCII in strict compliance with <i>RFC4180 Common Format and MIME Type for Comma-Separated Values (CSV) Files</i> . Trailing blanks are trimmed.
*XMLSS	Microsoft's Excel specific "XML Spreadsheet format" introduced with Excel 2002 and Excel 2003.
*OOXML	Office Open XML developed by Microsoft. Excel-erator implements the ISO/IEC 29500:2008 Strict specification, suitable for use with Excel 2010 and suitable for use with Excel 2007 if dates are not present in the spreadsheet. See http://en.wikipedia.org/wiki/Office_Open_XML for additional information.

Sheet name (SHEETNAME)

Specifies the name of the worksheet. CHAR(32)

Note: *BIFF4 does not support this value and it is ignored when TRANSFORM(*BIFF4) is specified.

*MBR	The member name is the sheet name.
character-value	Specify up to 32 characters enclosed in apostrophes.

Excel-erator provides several special values that can used to construct dynamic sheet names. When the special values are found, the associated data is blank trimmed and substituted into the name specified when it is processed. If the data associated with a special value is blank, "BLANK" is substituted. The special values must be delimited by an underscore (_) a period (.) or another special value (which starts with '*'). The result is trimmed if the length is exceeded.

*FILE	File name CHAR(10).
*FILELIB	Library containing the file CHAR(10).
*MBR	Member name CHAR(10).
*TEXT	Member Text 'description' CHAR(50).
*MBRCDAT	Date the member was created CHAR(7) CYYMMDD.
*MBRCCYY	CYY portion of *MBRCDAT CHAR(3).
*MBRCYY	YY portion of *MBRCDAT CHAR(2).
*MBRCMM	MM portion of *MBRCDAT CHAR(2).
*MBRCDD	DD portion of *MBRCDAT CHAR(2).
*MBRCTIM	Time the member was created CHAR(6) HHMMSS.
*MBRGDAT	Date the member was changed CHAR(7) CYYMMDD.
*MBRGYY	CYY portion of *MBRGDAT CHAR(3).
*MBRGYY	YY portion of *MBRGDAT CHAR(2).
*MBRGMM	MM portion of *MBRGDAT CHAR(2).
*MBRGDD	DD portion of *MBRGDAT CHAR(2).
*MBRGTIM	Time the member was changed CHAR(6) HHMMSS.

Sheet title (SHEETTITLE)

Specifies the title of the worksheet. CHAR(80)

Note: *BIFF4 does not support this value and it is ignored when TRANSFORM(*BIFF4) is specified.

Single values

*NONE	Title lines are not included in the sheet.
--------------	--

Other values (up to 5 repetitions)

character-value	Specify up to 80 characters enclosed in apostrophes.
------------------------	--

Add worksheet (ADDWS)

Specifies one or more worksheets to add to the generated spreadsheet by specifying the database file, member name, and list of fields used as source to add. CHAR(10), CHAR(10), CHAR(10) CHAR(10)

This is a required parameter.

Single values

***NONE** No additional worksheets are included.

Element 1: From file

The name and library of a database file.

Qualifier 1: From file	name	Specify the name of the file.
Qualifier 2: Library	*LIBL	All libraries in the thread's library list are searched.
	*CURLIB	Use the current library for the job. If no library is specified as the current library for the job, QGPL is used.
	name	Specify the name of the library.

Element 2: From member

*FIRST	The first member in the database from-file is processed.
*LAST	The last member in the database from-file is processed.
name	Specify the name of the database from-file member to process.

Element 3: Field

Single values	*ALL	All fields in the database file are included in the spreadsheet in the order they appear in the file.
Other values	name	Specify the list of field names to be included in the spreadsheet. The fields appear in the spreadsheet in the order specified, duplicates are allowed.

Element 5: Sheet name

Specifies the name of the worksheet. CHAR(32)

Note: *BIFF4 does not support this value and it is ignored when TRANSFORM(*BIFF4) is specified.

*MBR	The member name is the sheet name.
character-value	Specify up to 32 characters enclosed in apostrophes.

Excel-erator provides several special values that can be used to construct dynamic sheet names. When the special values are found, the associated data is blank trimmed and substituted into the name specified when it is processed. If the data associated with a special value is blank, "BLANK" is substituted. The special values must be delimited by an underscore (_) a period (.) or another special value (which starts with '*'). The result is trimmed if the length is exceeded.

*FILE	File name CHAR(10).
*FILELIB	Library containing the file CHAR(10).
*MBR	Member name CHAR(10).
*TEXT	Member Text 'description' CHAR(50).
*MBRCDAT	Date the member was created CHAR(7) CYYMMDD.
*MBRCCYY	CYY portion of *MBRCDAT CHAR(3).
*MBRCYY	YY portion of *MBRCDAT CHAR(2).
*MBRCMM	MM portion of *MBRCDAT CHAR(2).
*MBRCDD	DD portion of *MBRCDAT CHAR(2).
*MBRCTIM	Time the member was created CHAR(6) HHMMSS.
*MBRGDAT	Date the member was changed CHAR(7) CYYMMDD.
*MBRGYY	CYY portion of *MBRGDAT CHAR(3).
*MBRGYY	YY portion of *MBRGDAT CHAR(2).
*MBRGMM	MM portion of *MBRGDAT CHAR(2).

***MBRGDD** DD portion of *MBRGDAT CHAR(2).
***MBRGTIM** Time the member was changed CHAR(6) HHMMSS.

Element 6: Sheet title

Specifies the title of the worksheet. CHAR(80)

Note: *BIFF4 does not support this value and it is ignored when TRANSFORM(*BIFF4) is specified.

Single values ***NONE** Title lines are not included in the sheet.
Other values **character-value** Specify up to 80 characters enclosed in apostrophes.

Print header (PRTHEADER)

Specifies the print header placed in the spreadsheet. CHAR(50)

***NONE** No print header is included in the file.
***RCDTEXT** The record text is used as the print header.
***MBRTEXT** The member text is used as the print header.
***FILTEXT** The file text is used as the print header.
character-value Enter the value to use as the print header.

Print footer (PRTFOOTER)

Specifies the print footer placed in the spreadsheet. CHAR(50)

***NONE** No print footer is included in the file.
***RCDTEXT** The record text is used as the print footer.
***MBRTEXT** The member text is used as the print footer.
***FILTEXT** The file text is used as the print footer.
character-value Enter the value to use as the print footer.

Font typeface (FONT)

Specifies the font name placed into the file. The font specified must be available on the PC that is running Excel. CHAR(32).

***ARIAL** Font Arial is used.
***COURIER** Font Courier New, a fixed pitch font, is used.
character-value The name of the font to use.

Cell comments (COMMENT)

Specifies cell comments, consisting of a cell's coordinate column/row and the comment text, which are added to the generated spreadsheet. A comment can be added to a cell even if it does not contain data. INT(4) (where A=1, B=2, etc.), INT(4) CHAR(2048)

Single values

***NONE** No comments are added to the spreadsheet.

Element 1: Column

1-256 The column of the cell that receives the comment. You can use either a letter or number designation.

Element 2: Row

1-65536 The row of the cell that receives the comment.

Element 3: Text

character-value Enter the text that is to appear in the comment.

Target coded character set id (TRGCCSID)

Specifies the ASCII coded character set identifier (CCSID) that is used to map character data in the generated spreadsheet. INT(4)

Note: Only *BIFF4 supports this value and it is ignored unless TRANSFORM(*BIFF4) is specified.

1252 The default Windows coded character set identifier is used.
integer Specify the coded character set identifier to use.

Source coded character set id (SRCCSID)

Specifies the coded character set identifier (CCSID) used to create the spreadsheet. INT(4)

Note: Only *BIFF4 supports this value and it is ignored unless TRANSFORM(*BIFF4) is specified.

***KBDTYPE** The system determines the coded character set identifier value from the QKBDTYPE system value.
***SYSVAL** The system determines the coded character set identifier value from the QCHRID system value.
***JOBDFI** The system uses the current job's default coded character set identifier.
integer Specify the coded character set identifier to use.

Replace PC file data (REPLACE)

Specifies whether data in the PC file should be replaced if the object already exists. If the object does not exist, it is created. CHAR(1)

***YES** Data in an existing object is replaced.
***NO** Data in an existing object is not replaced and an error is generated.

Data authorities (DTAAUT)

Specifies the *PUBLIC data authorities assign to the created PC file. CHAR(10)

***ALL** The *PUBLIC is given *RWX authority to perform all operations on the object except those limited to the owner or controlled by object existence, object management, object alter, and object reference authority. The *PUBLIC can change the object and perform basic functions on the object. *RWX authority provides object operational authority and all the data authorities.

***NONE** The *PUBLIC does not have any of the data authorities to the object.

***RWX** The *PUBLIC is given *RWX authority to perform all operations on the object except those limited to the owner or controlled by object existence, object management, object alter, and object reference authority. The *PUBLIC can change the object and perform basic functions on the object. *RWX authority provides object operational authority and all the data authorities.

***RX** The *PUBLIC is given *RX authority to perform basic operations on the object, such as run a program or display the contents of a file. The user is prevented from changing the object. *RX authority provides object operational authority and read and execute authorities.

***RW** The *PUBLIC is given *RW authority to view the contents of an object and change the contents of an object. *RW authority provides object operational authority and data read, add, update, and delete authorities.

***WX** The *PUBLIC is given *WX authority to change the contents of an object and run a program or search a library or directory. *WX authority provides object operational authority and data add, update, delete, and execute authorities.

***R** The *PUBLIC is given *R authority to view the contents of an object. *R authority provides object operational authority and data read authority.

***W** The *PUBLIC is given *W authority to change the contents of an object. *W authority provides object operational authority and data add, update, and delete authorities.

***X** The *PUBLIC is given *X authority to run a program or search a library or directory. *X authority provides object operational authority and data execute authority.

***EXCLUDE** Exclude authority prevents the *PUBLIC from accessing the object.

***INHERIT** The *PUBLIC and other authorities to the object are copied as follows. The owner, primary group, and public data and object authorities (*R, *W, *X, *OBJEXIST, *OBJMGT, *OBJALTER, and *OBJREF) are copied from the parent directory's owner, primary group, and public data and object authorities. In addition, the private authorities (if any) and authorization list (if any) are copied from the parent directory. If the new file has a different owner

than the parent directory and the new file's owner has a private authority in the parent directory, that private authority is not copied from the parent directory. The authority for the owner of the new file is copied from the owner of the parent directory.

Create directories (CRTDIR)

Specifies whether directories in the object name should be created if they do not exist. CHAR(1)

- *NO** Directories are not created.
- *YES** Directories are created.

Owner (OWNER)

Specifies the user profile that is the owner of the newly created object. CHAR(10)

- *CURUSRPRF** The object is owned by the current effective user of the current job or thread.
- name*** Specify the user profile that is the owner of the newly created object. If the current effective user does not have *ADD data authority to the user profile, or if the profile does not exist, ownership of the object is determined in the same manner as *CURUSRPRF.

Object attribute (OBJATR)

Specifies additional attributes for the generated file and is similar in function to the CHGATR command. Each attribute is specified as an attribute/value pair. If an attribute is specified more than once, the last one wins. INT(4)

- *NONE** No additional attributes are specified.
- *DISKSTGOPT** Determines how auxiliary storage is allocated by the system for the object. This attribute can only be specified for byte stream files in the Root (/), QOpenSys and User-defined file systems. This attribute will be ignored for *TYPE1 byte stream files. Valid values are:
 - *NORMAL** The auxiliary storage will be allocated normally. That is, as additional auxiliary storage is required, it will be allocated in logically sized extents to accommodate the current space requirement, and anticipated future requirements, while minimizing the number of disk I/O operations. If the *DISKSTGOPT attribute has not been specified for an object, this value is the default.
 - *MINIMIZE** The auxiliary storage will be allocated to minimize the space used by the object. That is, as additional auxiliary storage is required, it will be allocated in small sized extents to accommodate the current space requirement. Accessing an object composed of many small extents may increase the number of disk I/O operations for that object.
 - *DYNAMIC** The system will dynamically determine the optimum auxiliary storage allocation for the object, balancing space used versus disk I/O operations. For example, if a file has many small extents, yet is frequently being read and written, then future auxiliary storage allocations will be larger extents to minimize the number of disk I/O operations. Or, if a file is frequently truncated, then future auxiliary storage allocations will be small extents to minimize the space used. Additionally, information will be maintained on the byte stream file sizes for this system and its activity. This file size information will also be used to help determine the optimum auxiliary storage allocations for this object as it relates to the other objects sizes.

File sharing (FILESHARE)

Specifies how the generated spreadsheet is secured. Each element corresponds to an Excel setting accessible from the "Save As" dialog. The limitations, and resulting encryption strength vary significantly between *BIFF8 and *BIFF4 and are documented separately.

For *BIFF8

Element 1: Password to open

- character-value*** Specifies the case sensitive password required to open and decrypt the file. If a password is not specified, the file is not encrypted and can be opened by anyone. CHAR(15)
Any character, including DBCS, can be included in the password. The spreadsheet is encrypted using the RC4

algorithm.

Element 2: Password to modify

character-value Specifies the case sensitive password required to update the file. If a password is specified and someone changes the file without the password, that person can save the file only by giving it a different name. If a password is not specified, the file can be updated by anyone. This password does not cause the file to be encrypted. CHAR(15)

Excel-erator restricts this password to a-z, A-Z, 0-9, the space character and symbols !"#%&'()*+,-./:;<=>?@[\\]^_`{|}~. That is the ascii code points from x20-x7E which map directly to UTF8 and the base plane of unicode. With this restriction, the password can be typed by virtually any recipient, without knowing the details of their keyboard or code page of their machine.

Note: The security of Password to modify is notoriously weak.

Element 3: Read-only recommended

***NO** No recommendation given. CHAR(1) value 'N'.

***YES** Specifies that users get a read-only (read-only: A setting that allows a file to be read or copied but not changed or saved.) recommendation when they open the file. This does not prevent users from opening the file as read-write so that they can edit and save changes. CHAR(1) value 'Y'.

For *BIFF4

*BIFF4 security is notoriously insecure and may not be suitable for all environments. Password crackers are freely available.

While not a requirement, for best results use a password that contains only characters a-z, A-Z, 0-9, the space character and symbols !"#%&'()*+,-./:;<=>?@[\\]^_`{|}~. This insures compatibility with Excel Macintosh edition, for example.

Element 1: Password to open

character-value Specifies the case sensitive password required to open and decrypt the file. If a password is not specified, the file is not encrypted and can be opened by anyone. CHAR(15)

Element 2: Password to modify

character-value Specifies the case sensitive password required to update the file. If a password is specified and someone changes the file without the password, that person can save the file only by giving it a different name. If a password is not specified, the file can be updated by anyone. This password does not cause the file to be encrypted. CHAR(15)

Element 3: Read-only recommended

***NO** No recommendation given. CHAR(1) value 'N'.

***YES** Specifies that users get a read-only (read-only: A setting that allows a file to be read or copied but not changed or saved.) recommendation when they open the file. This does not prevent users from opening the file as read-write so that they can edit and save changes. CHAR(1) value 'Y'.

Column heading format (COLHDFMT)

Specifies formatting applied to the cells containing column headings. Each element corresponds to an Excel setting accessible by selecting Format > Cells. The values that each element accepts have their usual Excel meanings with one exception: "Alignment-Horizontal" accepts a ***TYPE** special value, which is not available in Excel. When ***TYPE** is specified, the column headings of character fields are given ***LEFT** horizontal alignment while the column headings of numeric fields are given ***RIGHT** horizontal alignment. See Excel's help for additional information. Each element is INT(2).

Single values

***DEFAULT** Default values are used.

Element 1: Alignment-Horizontal INT(2)

Specifies alignment of text within cells.

*GENERAL	Cells are given Excel's "General" alignment.
*TYPE	Alignment is determined by the field's data type: right for numeric fields, left for character fields.
*LEFT	Cells are given Excel's "Left" alignment.
*CENTER	Cells are given Excel's "Center" alignment.
*RIGHT	Cells are given Excel's "Right" alignment.
*FILL	Cells are given Excel's "Fill" alignment.
*JUSTIFY	Cells are given Excel's "Justify" alignment.
*CENTERSEL	Cells are given Excel's "Center Across Selection" alignment.

Elements 2-5: Border-Line styles. INT(2)

Specify the Top/Left/Bottom/Right border line styles.

*NONE	Line is removed.
*THIN	Line is thin.
*MEDIUM	Line is medium.
*DASHED	Line is dashed.
*DOTTED	Line is dotted.
*THICK	Line is thick.
*DOUBLE	Line is doubled.
*HAIR	Line is hair.

Elements 6-9: Border-Line colors. INT(2)

Specify the Top/Left/Bottom/Right border line colors.

*SYSTEM	System default color.
*BLACK	Same as *COLOR1. Red=0, Green=0, Blue=0
*WHITE	Same as *COLOR2. Red=255, Green=255, Blue=255
*RED	Same as *COLOR3. Red=255, Green=0, Blue=0
*BRIGHTGREEN	Same as *COLOR4. Red=0, Green=255, Blue=0
*BLUE	Same as *COLOR5. Red=0, Green=0, Blue=255
*YELLOW	Same as *COLOR6. Red=255, Green=255, Blue=0
*PINK	Same as *COLOR7. Red=255, Green=0, Blue=255
*TURQUOISE	Same as *COLOR8. Red=0, Green=255, Blue=255
*DARKRED	Same as *COLOR9. Red=128, Green=0, Blue=0
*GREEN	Same as *COLOR10. Red=0, Green=128, Blue=0
*DARKBLUE	Same as *COLOR11. Red=0, Green=0, Blue=128
*DARKYELLOW	Same as *COLOR12. Red=128, Green=128, Blue=0
*VIOLET	Same as *COLOR13. Red=128, Green=0, Blue=128
*TEAL	Same as *COLOR14. Red=0, Green=128, Blue=128
*GRAY25	Same as *COLOR15. Red=192, Green=192, Blue=192
*GRAY50	Same as *COLOR16. Red=128, Green=128, Blue=128

Element 10: Patterns-Type INT(2)

Specifies the pattern to apply.

*NONE	No pattern is used.
*SOLID	Excel's "Solid" pattern.
*GRAY75	Excel's "75% Gray" pattern.
*GRAY50	Excel's "50% Gray" pattern.
*GRAY25	Excel's "25% Gray" pattern.
*GRAY12	Excel's "12.5% Gray" pattern.
*GRAY6	Excel's "6.25% Gray" pattern.
*STRIPEH50	Excel's "Horizontal Stripe" pattern.
*STRIPEH25	Excel's "Thin Horizontal Stripe" pattern.
*STRIPEV50	Excel's "Vertical Stripe" pattern.
*STRIPEV25	Excel's "Thin Vertical Stripe" pattern.

*STRIPED50	Excel's "Diagonal Stripe" pattern.
*STRIPED25	Excel's "Thin Diagonal Stripe" pattern.
*STRIPEDR50	Excel's "Reverse Diagonal Stripe" pattern.
*STRIPEDR25	Excel's "Thin Reverse Diagonal Stripe" pattern.
*HATCHD75	Excel's "Thick Diagonal Crosshatch" pattern.
*HATCHD50	Excel's "Diagonal Crosshatch" pattern.
*HATCHD38	Excel's "Thin Diagonal Crosshatch" pattern.
*HATCHH38	Excel's "Thin Horizontal Crosshatch" pattern.

Element 11-12: Patterns-Colors INT(2)

Specify the foreground and background pattern colors.

*AUTOMATIC	System default color.
*BLACK	Same as *COLOR1. Red=0, Green=0, Blue=0
*WHITE	Same as *COLOR2. Red=255, Green=255, Blue=255
*RED	Same as *COLOR3. Red=255, Green=0, Blue=0
*BRIGHTGREEN	Same as *COLOR4. Red=0, Green=255, Blue=0
*BLUE	Same as *COLOR5. Red=0, Green=0, Blue=255
*YELLOW	Same as *COLOR6. Red=255, Green=255, Blue=0
*PINK	Same as *COLOR7. Red=255, Green=0, Blue=255
*TURQUOISE	Same as *COLOR8. Red=0, Green=255, Blue=255
*DARKRED	Same as *COLOR9. Red=128, Green=0, Blue=0
*GREEN	Same as *COLOR10. Red=0, Green=128, Blue=0
*DARKBLUE	Same as *COLOR11. Red=0, Green=0, Blue=128
*DARKYELLOW	Same as *COLOR12. Red=128, Green=128, Blue=0
*VIOLET	Same as *COLOR13. Red=128, Green=0, Blue=128
*TEAL	Same as *COLOR14. Red=0, Green=128, Blue=128
*GRAY25	Same as *COLOR15. Red=192, Green=192, Blue=192
*GRAY50	Same as *COLOR16. Red=128, Green=128, Blue=128

Element 13: Protection-Locked INT(2)

Specifies if the cells are locked. Locking cells or hiding formulas has no effect unless the worksheet is protected.

*YES	Cells are locked.
*NO	Cells are not locked.

Color palette (PALETTE)

Specifies replacements for the default colors included in the spreadsheet's palette. The color palette is made up of the specification for sixteen colors, numbered 1 through 16, and assigned names such as *BLACK, *RED, etc. Each color in turn is made up of the specification for the amount of red, green, and blue (RGB) components that make up the color. The amount is a number between 0 and 255. The larger the amount, the more of the component present. You can determine the RGB values for a specific color using Excel's Tools > Options > Color > Custom tab. INT(2), INT(2), INT(2) repeated 16 times.

You specify a replacement for a default color by specifying its name and the new RGB values to use. If a color is modified then all references to the color's name, used in other parameters, are also modified. For example, if color *BLACK is changed to (255 106 0), color *BLACK becomes orange and all parameters that specify *BLACK will produce this orange.

Element 1: Color to replace

color-name Specify the name to modify, example *BLACK.

Element 2: Red component

integer Specify the red RGB component.

Element 3: Green component

integer Specify the green RGB component.

Element 4: Blue component

integer Specify the blue RGB component.

CSV separator character (CSVSEPCHR)

Specifies the character used to separator fields in the generated file. CHAR(1).

Note: This parameter is ignored for transforms except those that generate Comma Separated Value (CSV).

*COMMA	Values are separated by a ','.
*PERIOD	Values are separated by a '.'.
*PIPE	Values are separated by a ' '.
*SEMICOLON	Values are separated by a ';'.
*SLASH	Values are separated by a '/'.
*TAB	Values are separated by a horizontal tab.
character-value	Specify the character.

Examples

Example 1:

```
CPYTOEXCEL FROMFILE (CUSTOMER) TOOBJ ('/Excel/*FILE.XLS')
          CRTDIR (*YES)
```

This command converts file "CUSTOMER" into an Excel spreadsheet with the name "CUSTOMER.XLS". The spreadsheet is placed in the "Excel" directory, which is created if it does not exist.

Example 2:

```
CPYTOEXCEL FROMFILE (INVOICE)
          TOOBJ ('/QNTC/NT1/C/ardept/invoice.*MBRCDAT.xls')
```

This command converts file "INVOICE" into an Excel spreadsheet with the name "INVOICE.cyymmdd.XLS" (where the from member's creation date is substituted for cyymmdd). The spreadsheet is placed on a Windows system with the name "NT1" in subdirectory "ardept" of the "C" share.

Error messages

Parameter dependencies

XL17003	When ADDWS() is specified, TRANSFORM(*BIFF8/*XMLSS/*OOXML) must be specified.
XL17004	When SHEETNAME() is specified TRANSFORM(*BIFF8/*XMLSS/*OOXML) must be specified.
XL17005	When SHEETTITLE() is specified TRANSFORM(*BIFF8/*XMLSS/*OOXML) must be specified.
XL17006	When TRANSFORM(*BIFF4) is specified COLHDG(*COLHD1) and COLHDG(*COLHD1BLD) can not be specified.
XL17007	When PRTHEADER() is specified TRANSFORM(*BIFF8/*BIFF4/*XMLSS/*OOXML) must be specified.
XL17008	When PRTFOOTER() is specified TRANSFORM(*BIFF8/*BIFF4/*XMLSS/*OOXML) must be specified.
XL17008	When FONT() is specified TRANSFORM(*BIFF8/*BIFF4/*XMLSS/*OOXML) must be specified.
XL17008	When COMMENT() is specified TRANSFORM(*BIFF8/*BIFF4/*XMLSS/*OOXML) must be specified.
XL17008	When TRGCCSID() is specified TRANSFORM(*BIFF4) must be specified.
XL17008	When SRCCSID() is specified TRANSFORM(*BIFF4) must be specified.
XL17008	When FILESHARE() is specified TRANSFORM(*BIFF8/*BIFF4) must be specified.
XL17008	When COLHDGFMTO() is specified TRANSFORM(*BIFF8/*BIFF4/*XMLSS/*OOXML) must be specified.
XL17008	When PALETTE() is specified TRANSFORM(*BIFF8/*BIFF4/*XMLSS/*OOXML) must be specified.
SCV7001	CSV Separator character ',' required with TRANSFORM(*CSVRFC).

Display Mail Log (DSPMAILLOG)

Where allowed to run: All environments (*ALL)

Threadsafe: No

The Display Mail Log (DSPMAILLOG) command shows the system mail log (journal QZMF). The mail log contains information about the processing of mail.

Note: Mail journaling must be turned on. Only journal receivers in the current chain are searched.

Parameters

Keyword	Description	Choices	Notes
PERIOD	Time period	<i>Element list</i>	Optional, Positional 1
	Element 1: Starting time and date	<i>Element list</i>	
	Element 1: Starting time	<i>Time, *AVAIL</i>	
	Element 2: Starting date	<i>Date, *CURRENT, *BEGIN</i>	
	Element 2: Ending time and date	<i>Element list</i>	
	Element 1: Ending time	<i>Time, *AVAIL</i>	
	Element 2: Ending date	<i>Date, *CURRENT, *END</i>	
OUTPUT	Output	<i>_, *PRINT</i>	Optional, Positional 2

Time period (PERIOD)

Specifies the period of time for which the logged message data is shown. This parameter contains two lists of two elements each.

Element 1: Starting time and date

Element 1: Starting time One of the following specifies the starting time from which entries are shown. Entries logged before this time on the **Starting date** are not shown.

***AVAIL**
time

All data that is available for the specified date is shown.

Specify the start time from which data for the specified date is shown. The time is specified in 24-hour format and can be specified with or without a time separator:

- Without a time separator, specify 4 or 6 digits (hhmm or hhmmss) where hh = hours, mm = minutes, and ss = seconds. Hours, minutes and seconds must each be 2 digits; use leading zeros if necessary.
- With a time separator, specify 5 or 8 digits where the time separator specified for your job is used to separate the hours, minutes, and seconds.

Element 2: Starting date One of the following specifies the starting date from which entries are shown. Entries logged before this date are not shown.

***CURRENT**
***BEGIN**
date

The current date is used.

The data from the beginning of the log is shown.

Specify the start date from which data is shown. The date must be specified in the job date format.

Element 2: Ending time and date

Element 1: Ending time One of the following specifies the ending time to which entries are shown. Entries logged after this time on the **Ending date** are not shown.

***AVAIL**
time

All data that is available for the specified date is shown.

Specify the end time to which data for the specified date is shown. See **start-date** for the formats in which time can be entered.

Element 2: Ending date One of the following specifies the ending date to which entries are shown. Entries logged after this date are not shown.

***CURRENT**
***END**
date

The current date is used.

The data to the end of the log is shown.

Specify the end date to which data is shown. The date must be specified in the job date format.

Output (OUTPUT)

Specifies whether the output from the command is shown at the requesting display station or printed with the job's spooled output.

<code>*</code>	Output requested by an interactive job is shown on the display. Output requested by a batch job is printed with the job's spooled output.
<code>*PRINT</code>	The output is printed with the job's spooled output.

Examples

Example 1:

```
DSPMAILLOG
```

The mail log entries for today are displayed on the screen.

Example 2:

```
DSPMAILLOG PERIOD ( (*AVAIL *BEGIN) (*AVAIL *END) )  
              OUTPUT ( *PRINT )
```

All available mail log entries in the current journal receiver chain are printed.

Restart/Purge Local Mail (INZLOCAL)

Where allowed to run: All environments (*ALL)

Threadsafe: No

The Restart/Purge Local Mail (INZLOCAL) command ends and restarts IBM i mail components. This may be required to clear problems or to make configuration changes immediately effective.

Parameters

Keyword	Description	Choices	Notes
SMTP	Restart SMTP server	<u>*YES</u> , *NO, Y, N	Optional, Positional 1
SMTTPURGE	Clear SMTP during restart	<u>*NO</u> , *YES, Y, N	Optional, Positional 2
MSF	Restart MSF server	<u>*YES</u> , *NO, Y, N	Optional, Positional 3
MSFPURGE	Clear MSF during restart	<u>*NO</u> , *YES, Y, N	Optional, Positional 4

Restart SMTP server (SMTP)

Specifies the whether the SMTP server is restarted.

- *YES The SMTP server is first ended then started.
- *NO The command does not restart the SMTP server.

Clear SMTP during restart (SMTTPURGE)

Specifies the whether the SMTP server is purged during the restart.

Note: Clear means that all IBM i SMTP email will be deleted. If you are not sure, select *NO.

- *NO Existing messages are not cleared.
- *YES Existing messages are cleared.

Restart MSF server (MSF)

Specifies the whether the MSF server is restarted.

- *YES The MSF server is first ended then started.
- *NO The command does not restart the MSF server.

Clear MSF during restart (MSFPURGE)

Specifies the whether the MSF server is cleared during the restart.

Note: Clear means that mail server framework distributions (emails) will be deleted from this system. If you are not sure, select *NO.

- *NO The MSF is not cleared.
- *YES The MSF is cleared.

Examples

Example 1:

```
INZLOCAL
```

This command restarts the SMTP server and Mail Server Framework jobs.

Example 2:

```
INZLOCAL      SMTPPURGE (*YES) MSFPURGE (*YES)
```

This command restarts the SMTP server and Mail Server Framework jobs after purging all data they contain.

Error messages**Parameter dependencies**

MSU7012	SMTP cannot be cleared unless it is also restarted.
MSU7013	MSF cannot be cleared unless it is also restarted.

Ping SMTP Mail Server (PINGMAIL)

Where allowed to run: All environments (*ALL)

Threadsafe: No

The Ping SMTP Mail Server (PINGMAIL) command establishes an SMTP connection with a remote system to insure it will process email from the local System i.

The detailed send and receive data from the connection is recorded in the joblog and can be view using the Display Job Log (DSPJOBLOG) command.

Parameters

Keyword	Description	Choices	Notes
RMTSYS	Remote system	Character value, *INTNETADR	Required, Positional 1
SMTPNAME	To SMTP name (email address)	Character value, *NONE	Optional
SMTPNAME2	From SMTP name (email address)	Character value, *SMTPNAME	Optional
AUTHUSRNAM	Authentication username	Character value, *NONE	Optional
AUTHPWD	Authentication password	Character value	Optional
PORT	Port	0-65534, 25	Optional
INTNETADR	Remote internet address	Character value	Optional

Remote system (RMTSYS)

Specifies the remote system name of the host with which the Ping SMTP Mail Server operation takes place. To be successful, the name must be valid, and the remote system must be able to communicate with the local system.

This is a required parameter.

***INTNETADR** The INTNETADR parameter is used.
character-value Specify the remote system name to use.

To SMTP name (email address) (SMTPNAME)

Specifies an email address to verify with the remote host. A short email message is sent to the address. The message is inserted directly into the mail router under test, bypassing all of IBM i's mail machinery. This makes it is easier to determine if a mail delivery problem is most likely caused by the mail router or by IBM i's configuration.

***NONE** An email address is not specified.
character-value Specify the email address to use.

From SMTP name (email address) (SMTPNAME2)

Specifies the from email address included in the test message.

***SMTPNAME** The To SMTP name (email address) is used as the From SMTP name (email address).
character-value Specify the email address to use.

Authentication username (AUTHUSRNAM)

Specifies the user name used to authenticate with the remote system.

***NONE** Authentication is not performed.
character-value Specify the user name to send to the remote system for authentication.

Authentication password (AUTHPWD)

Specifies the password used to authenticate with the remote system.

character-value Specify the password to send to the remote system for authentication.

Port (PORT)

Specifies the port on which the remote system is listening.

25 Use the well-known port 25 for SMTP.

integer Specify any port in the range of 1 to 65534 on which the remote system is listening for SMTP connections.

Remote internet address (INTNETADR)

Specifies the remote internet address. The internet address is specified in the form **nnn.nnn.nnn.nnn**, where **nnn** is a decimal number ranging from 0 through 255. An internet address is not valid if it has a value of all binary ones or all binary zeros for the network identifier (ID) portion or the host ID portion of the address. If the internet address is entered from a command line, enclose the address in apostrophes.

character-value Specify the internet address of the remote system. If the internet address is entered from a command line, enclose the address in apostrophes.

Examples

Example 1:

```
PINGMAIL RMTSYS(system2.widget.com)
```

This command tests system2 in the widget.com domain to insure that it will process email.

Example 2:

```
PINGMAIL RMTSYS(*INTNETADR INTNETADR('168.243.199.2'))
```

This command tests the system at IP address 168.243.199.2 to insure that it will process email.

Error messages

Parameter dependencies

MSU7009 When *INTNETADR is specified Remote internet address must be specified.

MSU7010 RMTSYS(*INTNETADR) required when INTNETADR is specified.

Send File Excel (SNDFEXCEL)

Where allowed to run: All environments (*ALL)

Threading: No

The Send File Excel (SNDFEXCEL) command converts one or more IBM i database files into Excel spreadsheets which are then sent as an email to recipients.

Parameters

Keyword	Description	Choices	Notes
SNDF	File specifications	Values (up to 32 repetitions): <i>Element list</i>	Required, Positional 1
	Element 1: From file	<i>Qualified object name</i>	
	Qualifier 1: From file	<i>Name</i>	
	Qualifier 2: Library	<i>Name, *LIBL, *CURLIB</i>	
	Element 2: Attachment file name	<i>Character value, *FILE, *TRNEXT, *APPEND, *FILE, *FILELIB, *TRNEXT, *MBR, *TEXT, *MBRCDAT, *MBRCCYY, *MBRCYY, *MBRCMM, *MBRCDD, *MBRCTIM, *MBRGDAT, *MBRGCYY, *MBRGYY, *MBRGMM, *MBRGDD, *MBRGTIM</i>	
	Element 3: From member	<i>Name, *FIRST, *LAST</i>	
	Element 4: Field	Single values: <i>*ALL</i> Other values (up to 256 repetitions): <i>Name</i>	
Element 5: Sheet name	<i>Character value, *FILE, *FILELIB, *MBR, *TEXT, *MBRCDAT, *MBRCCYY, *MBRCYY, *MBRCMM, *MBRCDD, *MBRCTIM, *MBRGDAT, *MBRGCYY, *MBRGYY, *MBRGMM, *MBRGDD, *MBRGTIM</i>		
Element 6: Sheet title	Single values: <i>*NONE</i> Other values (up to 5 repetitions): <i>Character value</i>		
TO	To (recipient)	Single values: <i>*CURRENT, *NONE</i> Other values (up to 300 repetitions): <i>Element list</i>	Optional, Positional 2
	Element 1:	<i>Character value</i>	
SUBJECT	Subject	<i>Character value, *DEFAULT, *NONE</i>	Optional, Positional 3
COLHDG	Column headings	<i>*FLDNAM, *ALIAS, *COLHDG, *COLHD1, *NONE, *FLDNAMBLD, *ALIASBLD, *COLHDGBLD, *COLHD1BLD</i>	Optional
TRANSFORM	Transform	<i>*BIFF8, *CSVUTF8, *CSVUTF8M, *CSVRFC, *BIFF4, *XMLSS, *OOXML</i>	Optional
PRTHEADER	Print header	<i>Character value, *RCDTEXT, *MBRTEXT, *FILTEXT, *NONE</i>	Optional
PRTFOOTER	Print footer	<i>Character value, *RCDTEXT, *MBRTEXT, *FILTEXT, *NONE</i>	Optional
FONT	Font typeface	<i>Character value, *ARIAL, *COURIER</i>	Optional
COMMENT	Cell comments	Single values: <i>*NONE</i> Other values (up to 32 repetitions): <i>Element list</i>	Optional
	Element 1: Column	1-256, <u>A</u> , B, C, D, E, F, G, H, I, J, K, L, M, N, O, P, Q, R, S, T, U, V, W, X, Y, Z, AA, AB, AC, AD, AE, AF, AG, AH, AI, AJ, AK, AL, AM, AN, AO, AP, AQ, AR, AS, AT, AU, AV, AW, AX, AY, AZ, BA, BB, BC, BD, BE, BF, BG, BH, BI, BJ, BK, BL, BM, BN, BO, BP, BQ, BR, BS, BT, BU, BV, BW, BX, BY, BZ, CA, CB, CC, CD, CE, CF, CG, CH, CI, CJ, CK, CL, CM, CN, CO, CP, CQ, CR, CS, CT, CU, CV, CW, CX, CY, CZ, DA, DB, DC, DD, DE, DF, DG, DH, DI, DJ, DK, DL, DM, DN, DO, DP, DQ, DR, DS, DT, DU, DV, DW, DX, DY, DZ, EA, EB, EC, ED, EE, EF, EG, EH, EI, EJ, EK, EL, EM, EN, EO, EP, EQ, ER, ES, ET, EU, EV, EW, EX, EY, EZ, FA, FB, FC, FD, FE, FF, FG, FH, FI, FJ, FK, FL, FM, FN, FO, FP, FQ, FR, FS, FT, FU, FV, FW, FX, FY, FZ, GA, GB, GC, GD, GE, GF, GG, GH, GI, GJ, GK, GL, GM, GN, GO, GP, GQ, GR, GS, GT, GU, GV, GW, GX, GY, GZ, HA, HB, HC, HD, HE, HF, HG, HH, HI, HJ, HK, HL, HM, HN, HO, HP, HQ, HR, HS, HT, HU, HV, HW, HX, HY, HZ, IA, IB, IC, ID, IE, IF, IG, IH, II, IJ, IK, IL, IM, IN, IO, IP, IQ, IR, IS, IT, IU, IV	
	Element 2: Row	1-65536, <u>1</u>	
	Element 3: Text	<i>Character value</i>	
MSG	Message	<i>Character value, *DEFAULT, *NONE</i>	Optional
CC	Cc (carbon copy)	Single values: <i>*NONE</i> Other values (up to 300 repetitions): <i>Element list</i>	Optional
	Element 1:	<i>Character value, *CURRENT, *USRID</i>	
BCC	Bcc (blind carbon copy)	Single values: <i>*NONE</i> Other values (up to 300 repetitions): <i>Element list</i>	Optional
	Element 1:	<i>Character value, *CURRENT, *USRID</i>	

FROM	From (originator)	<i>Character value</i> , *CURRENT	Optional
CFMDEL	Confirmation of delivery	*NO , *YES, *OBS, Y, N, O	Optional
REPLYTO	Reply to	Single values: *NONE Other values (up to 300 repetitions): <i>Element list</i>	Optional
	Element 1:	<i>Character value</i> , *CURRENT, *USRID	
INCOBJ	Include object	Single values: *NONE Other values (up to 64 repetitions): <i>Element list</i>	Optional
	Element 1: Name	<i>Path name</i>	
	Element 2: Send as	*NOTE, *ATTACH , *TEXTPLAIN, *TEXTHTML, *ATTACHPDF, *ATTACHPS	
CHRENC	Character encoding of mail	*UTF8 , *ISO88591, *ISO88592, *ISO88595, *ISO88596, *ISO88597, *ISO88598, *ISO88599, *BIG5, 1208, 819, 912, 915, 1089, 813, 916, 920, 950	Optional
TRGCCSID	Target coded character set id	1-65533, 1252	Optional
SRCCSID	Source coded character set id	1-65533, *KBDTYPE , *SYSVAL, *JOBDFIT	Optional
FILESHARE	File sharing	<i>Element list</i>	Optional
	Element 1: Password to open	<i>Character value</i>	
	Element 2: Password to modify	<i>Character value</i>	
	Element 3: Read-only recommended	*YES, *NO , Y, N	
COLHDGFM	Column heading format	Single values: *DEFAULT Other values: <i>Element list</i>	Optional
	Element 1: Alignment-Horizontal	*GENERAL , *TYPE, *LEFT, *CENTER, *RIGHT, *FILL, *JUSTIFY, *CENTERSEL, 0, 1, 2, 3, 4, 5, 6, 8	
	Element 2: Border-Top line style	*NONE , *THIN, *MEDIUM, *DASHED, *DOTTED, *THICK, *DOUBLE, *HAIR, 0, 1, 2, 3, 4, 5, 6, 7	
	Element 3: Border-Left line style	*NONE , *THIN, *MEDIUM, *DASHED, *DOTTED, *THICK, *DOUBLE, *HAIR, 0, 1, 2, 3, 4, 5, 6, 7	
	Element 4: Border-Bottom line style	*NONE , *THIN, *MEDIUM, *DASHED, *DOTTED, *THICK, *DOUBLE, *HAIR, 0, 1, 2, 3, 4, 5, 6, 7	
	Element 5: Border-Right line style	*NONE , *THIN, *MEDIUM, *DASHED, *DOTTED, *THICK, *DOUBLE, *HAIR, 0, 1, 2, 3, 4, 5, 6, 7	
	Element 6: Border-Top line color	*SYSTEM , *BLACK, *WHITE, *RED, *BRIGHTGREEN, *BLUE, *YELLOW, *PINK, *TURQUOISE, *DARKRED, *GREEN, *DARKBLUE, *DARKYELLOW, *VIOLET, *TEAL, *GRAY25, *GRAY50, *COLOR1, *COLOR2, *COLOR3, *COLOR4, *COLOR5, *COLOR6, *COLOR7, *COLOR8, *COLOR9, *COLOR10, *COLOR11, *COLOR12, *COLOR13, *COLOR14, *COLOR15, *COLOR16, 32767, 8, 9, 10, 11, 13, 14, 15, 16, 17, 18, 19, 20, 21, 22, 23	
	Element 7: Border-Left line color	*SYSTEM , *BLACK, *WHITE, *RED, *BRIGHTGREEN, *BLUE, *YELLOW, *PINK, *TURQUOISE, *DARKRED, *GREEN, *DARKBLUE, *DARKYELLOW, *VIOLET, *TEAL, *GRAY25, *GRAY50, *COLOR1, *COLOR2, *COLOR3, *COLOR4, *COLOR5, *COLOR6, *COLOR7, *COLOR8, *COLOR9, *COLOR10, *COLOR11, *COLOR12, *COLOR13, *COLOR14, *COLOR15, *COLOR16, 32767, 8, 9, 10, 11, 13, 14, 15, 16, 17, 18, 19, 20, 21, 22, 23	
	Element 8: Border-Bottom line color	*SYSTEM , *BLACK, *WHITE, *RED, *BRIGHTGREEN, *BLUE, *YELLOW, *PINK, *TURQUOISE, *DARKRED, *GREEN, *DARKBLUE, *DARKYELLOW, *VIOLET, *TEAL, *GRAY25, *GRAY50, *COLOR1, *COLOR2, *COLOR3, *COLOR4, *COLOR5, *COLOR6, *COLOR7, *COLOR8, *COLOR9, *COLOR10, *COLOR11, *COLOR12, *COLOR13, *COLOR14, *COLOR15, *COLOR16, 32767, 8, 9, 10, 11, 13, 14, 15, 16, 17, 18, 19, 20, 21, 22, 23	
	Element 9: Border-Right line color	*SYSTEM , *BLACK, *WHITE, *RED, *BRIGHTGREEN, *BLUE, *YELLOW, *PINK, *TURQUOISE, *DARKRED, *GREEN, *DARKBLUE, *DARKYELLOW, *VIOLET, *TEAL, *GRAY25, *GRAY50, *COLOR1, *COLOR2, *COLOR3, *COLOR4, *COLOR5, *COLOR6, *COLOR7, *COLOR8, *COLOR9, *COLOR10, *COLOR11, *COLOR12, *COLOR13, *COLOR14, *COLOR15, *COLOR16, 32767, 8, 9, 10, 11, 13, 14, 15, 16, 17, 18, 19, 20, 21, 22, 23	
	Element 10: Patterns-Type	*NONE , *SOLID, *GRAY75, *GRAY50, *GRAY25, *GRAY12, *GRAY6, *STRIPEH50, *STRIPEH25, *STRIPEV50, *STRIPEV25, *STRIPED50, *STRIPED25, *STRIPEDR50, *STRIPEDR25, *HATCHD75, *HATCHD50, *HATCHD38, *HATCHH38, 0, 1, 2, 3, 4, 5, 6, 7, 8, 9, 10, 11, 12, 13, 14, 15, 16, 17, 18	
Element 11: Patterns-Foreground color	*AUTOMATIC , *BLACK, *WHITE, *RED, *BRIGHTGREEN, *BLUE, *YELLOW, *PINK, *TURQUOISE, *DARKRED, *GREEN, *DARKBLUE, *DARKYELLOW, *VIOLET, *TEAL, *GRAY25, *GRAY50, *COLOR1, *COLOR2, *COLOR3, *COLOR4, *COLOR5, *COLOR6, *COLOR7, *COLOR8, *COLOR9, *COLOR10, *COLOR11,		

		*COLOR12, *COLOR13, *COLOR14, *COLOR15, *COLOR16, 24, 8, 9, 10, 11, 13, 14, 15, 16, 17, 18, 19, 20, 21, 22, 23	
	Element 12: Patterns-Background color	* AUTOMATIC , *BLACK, *WHITE, *RED, *BRIGHTGREEN, *BLUE, *YELLOW, *PINK, *TURQUOISE, *DARKRED, *GREEN, *DARKBLUE, *DARKYELLOW, *VIOLET, *TEAL, *GRAY25, *GRAY50, *COLOR1, *COLOR2, *COLOR3, *COLOR4, *COLOR5, *COLOR6, *COLOR7, *COLOR8, *COLOR9, *COLOR10, *COLOR11, *COLOR12, *COLOR13, *COLOR14, *COLOR15, *COLOR16, 25, 8, 9, 10, 11, 13, 14, 15, 16, 17, 18, 19, 20, 21, 22, 23	
	Element 13: Protection-Locked	* YES , *NO, 0, 1	
PALETTE	Color palette	Values (up to 16 repetitions): <i>Element list</i>	Optional
	Element 1: Color to replace	*BLACK, *WHITE, *RED, *BRIGHTGREEN, *BLUE, *YELLOW, *PINK, *TURQUOISE, *DARKRED, *GREEN, *DARKBLUE, *DARKYELLOW, *VIOLET, *TEAL, *GRAY25, *GRAY50	
	Element 2: Red component	0-255	
	Element 3: Green component	0-255	
	Element 4: Blue component	0-255	
SGNKEY	Signing key	Single values: * DEFAULT , *NONE Other values: <i>Element list</i>	Optional
	Element 1: Application ID	<i>Character value</i>	
CSVSEPCHR	CSV separator character	<i>Character value</i> , * COMMA , *PERIOD, *PIPE, *SEMICOLON, *SLASH, *TAB	Optional
TOUSRID	To (distribution list)	Single values: * NONE Other values: <i>Element list</i>	Optional
	Element 1: User ID	<i>Character value</i>	
	Element 2: Address	<i>Character value</i>	

File specifications (SNDF)

Specifies one or more database files that are sent, the attachment file name for each file as it appears in the email, the member name to be sent for each file, and the list of fields to be included for each file. CHAR(10), CHAR(10), CHAR(32), CHAR(10), CHAR(10), CHAR(80)

This is a required parameter.

Element 1: From file

The name and library of a database file.

Qualifier 1: From file	name	Specify the name of the file.
Qualifier 2: Library	* LIBL	All libraries in the thread's library list are searched.
	* CURLIB	Use the current library for the job. If no library is specified as the current library for the job, QGPL is used.
	name	Specify the name of the library.

Element 2: Attachment file name

* FILE.*TRNEXT	The name is made up of the database file name with an extension based on the transform specified.
* APPEND	The database file does not result in a separate Excel spreadsheet. Instead, a worksheet is generated and appended (added to) the preceding Excel spreadsheet.
	Note: When this value is used, it must be the only value entered in the command element.
name	Specify the name of the attached file.

Excel-erator provides several special values that can be used to construct dynamic object (PC file) names. When the special values are found, the associated data is blank trimmed and substituted into the path specified when it is processed. If the data associated with a special value is blank, "BLANK" is substituted. If the data associated with a special value contains characters not allowed in an object name, question marks (?) for example, the name will be invalid and the command will fail. The special values must be delimited by an underscore (_) a period (.) a slash (/ or \) or another special value (which starts with *).

The transform related special values are:

* TRNEXT	Transform dependent file extension CHAR(3) or CHAR(4).
-----------------	--

- XLS for *BIFF8 or *BIFF4.
- csv for *CSVUTF8, *CSVUTF8M or *CSVRFC.
- xml for *XMLSS.
- xlsx for *OOXML.

The member related special values are:

*FILE	File name CHAR(10).
*FILELIB	Library containing the file CHAR(10).
*MBR	Member name CHAR(10).
*TEXT	Member Text 'description' CHAR(50).
*MBRCDAT	Date the member was created CHAR(7) CYYMMDD.
*MBRCCYY	CYY portion of *MBRCDAT CHAR(3).
*MBRCYY	YY portion of *MBRCDAT CHAR(2).
*MBRCMM	MM portion of *MBRCDAT CHAR(2).
*MBRCDD	DD portion of *MBRCDAT CHAR(2).
*MBRCTIM	Time the member was created CHAR(6) HHMMSS.
*MBRGDAT	Date the member was changed CHAR(7) CYYMMDD.
*MBRGCYY	CYY portion of *MBRGDAT CHAR(3).
*MBRGYY	YY portion of *MBRGDAT CHAR(2).
*MBRGMM	MM portion of *MBRGDAT CHAR(2).
*MBRGDD	DD portion of *MBRGDAT CHAR(2).
*MBRGTIM	Time the member was changed CHAR(6) HHMMSS.

Element 3: From member

*FIRST	The first member in the database from-file is processed.
*LAST	The last member in the database from-file is processed.
name	Specify the name of the database from-file member to process.

Element 4: Field

Single values	*ALL	All fields in the database file are included in the spreadsheet in the order they appear in the file.
Other values	name	Specify the list of field names to be included in the spreadsheet. The fields appear in the spreadsheet in the order specified, duplicates are allowed.

Element 5: Sheet name

Specifies the name of the worksheet. CHAR(32)

Note: *BIFF4 does not support this value and it is ignored when TRANSFORM(*BIFF4) is specified.

*MBR	The member name is the sheet name.
character-value	Specify up to 32 characters enclosed in apostrophes.

Excel-erator provides several special values that can be used to construct dynamic sheet names. When the special values are found, the associated data is blank trimmed and substituted into the name specified when it is processed. If the data associated with a special value is blank, "BLANK" is substituted. The special values must be delimited by an underscore (_) a period (.) or another special value (which starts with '*'). The result is trimmed if the length is exceeded.

*FILE	File name CHAR(10).
*FILELIB	Library containing the file CHAR(10).
*MBR	Member name CHAR(10).
*TEXT	Member Text 'description' CHAR(50).
*MBRCDAT	Date the member was created CHAR(7) CYYMMDD.
*MBRCCYY	CYY portion of *MBRCDAT CHAR(3).
*MBRCYY	YY portion of *MBRCDAT CHAR(2).
*MBRCMM	MM portion of *MBRCDAT CHAR(2).
*MBRCDD	DD portion of *MBRCDAT CHAR(2).

*MBRCTIM	Time the member was created CHAR(6) HHMMSS.
*MBRGDAT	Date the member was changed CHAR(7) CYYMMDD.
*MBRG CYY	CYY portion of *MBRGDAT CHAR(3).
*MBRGYY	YY portion of *MBRGDAT CHAR(2).
*MBRGMM	MM portion of *MBRGDAT CHAR(2).
*MBRGDD	DD portion of *MBRGDAT CHAR(2).
*MBRGTIM	Time the member was changed CHAR(6) HHMMSS.

Element 6: Sheet title

Specifies the title of the worksheet. CHAR(80)

Single values ***NONE** Title lines are not included in the sheet.

Note: *BIFF4 does not support this value and it is ignored when TRANSFORM(*BIFF4) is specified.

Other values **character-value** Specify up to 80 characters enclosed in apostrophes.

To (recipient) (TO)

Specifies the email address(es) to which the generated email is sent. Up to 300 addresses can be specified. CHAR(128)

Single values

***CURRENT** The email address stored in the directory entry associated with the user running the command is used.

***NONE** An email address is not specified.

Other values (up to 300 repetitions)

character-value Specify the email address of the recipient.

Subject (SUBJECT)

Specifies the subject for the generated email. CHAR(60)

***DEFAULT** The subject of the email is generated from the file specification.

***NONE** No subject is included in the email.

character-value Specify the subject of the email.

Column headings (COLHDG)

Specifies the column headings generated. CHAR(10)

***FLDNAM** The file's field names are used as column headings.

***ALIAS** The file's field aliases are used as column headings.

***COLHDG** The file's field column headings are used as column headings.

***COLHD1** The file's field column headings are used as column headings. A heading with multiple lines is text wrapped into a single cell.

***NONE** No column headings are included.

***FLDNAMBLD** The file's field names are used as column headings. The column headings are bold.

***ALIASBLD** The file's field aliases are used as column headings. The column headings are bold.

***COLHDGBLD** The file's field column headings are used as column headings. The column headings are bold.

***COLHD1BLD** The file's field column headings are used as column headings. A heading with multiple lines is text wrapped into a single cell. The column headings are bold.

Transform (TRANSFORM)

Specifies the target format to which the data is transformed. CHAR(10).

***BIFF8** Microsoft's Binary Interchange File Format Version 8, the format used by Excel version 8.0 (Excel 97/98), Excel

	9.0 (Excel 2000/2001), Excel 10.0 (Excel XP/v.X) and Excel 11.0 (Excel 2003/2004).
*BIFF4	Microsoft's Binary Interchange File Format Version 4, the format used by Excel version 4.0 (Excel 4.0). Note: *BIFF4 is include for compatibility reasons and its use is not recommended in preference to *BIFF8
*CSVUTF8	Comma Separated Values (CSV) format. Data is converted to UTF-8. Trailing blanks are trimmed.
*CSVUTF8M	Comma Separated Values (CSV) format. Data is converted to UTF-8 and Byte Order Mark xEFBBBF is inserted at the start of the file. Trailing blanks are trimmed.
*CSVRFC	Comma Separated Values (CSV) format. Data is converted to US-ASCII in strict compliance with <i>RFC4180 Common Format and MIME Type for Comma-Separated Values (CSV) Files</i> . Trailing blanks are trimmed.
*XMLSS	Microsoft's Excel specific "XML Spreadsheet format" introduced with Excel 2002 and Excel 2003.
*OOXML	Office Open XML developed by Microsoft. Excel-erator implements the ISO/IEC 29500:2008 Strict specification, suitable for use with Excel 2010 and suitable for use with Excel 2007 if dates are not present in the spreadsheet. See http://en.wikipedia.org/wiki/Office_Open_XML for additional information.

Print header (PRTHEADER)

Specifies the print header placed in the spreadsheet. CHAR(50)

*NONE	No print header is included in the file.
*RCDFTEXT	The record text is used as the print header.
*MBRTEXT	The member text is used as the print header.
*FILTEXT	The file text is used as the print header.
character-value	Enter the value to use as the print header.

Print footer (PRTFOOTER)

Specifies the print footer placed in the spreadsheet. CHAR(50)

*NONE	No print footer is included in the file.
*RCDFTEXT	The record text is used as the print footer.
*MBRTEXT	The member text is used as the print footer.
*FILTEXT	The file text is used as the print footer.
character-value	Enter the value to use as the print footer.

Font typeface (FONT)

Specifies the font name placed into the file. The font specified must be available on the PC that is running Excel. CHAR(32).

*ARIAL	Font Arial is used.
*COURIER	Font Courier New, a fixed pitch font, is used.
character-value	The name of the font to use.

Cell comments (COMMENT)

Specifies cell comments, consisting of a cell's coordinate column/row and the comment text, which are added to the generated spreadsheet. A comment can be added to a cell even if it does not contain data. INT(4) (where A=1, B=2, etc.), INT(4) CHAR(2048)

Single values

*NONE	No comments are added to the spreadsheet.
--------------	---

Element 1: Column

1-256	The column of the cell that receives the comment. You can use either a letter or number designation.
--------------	--

Element 2: Row

1-65536	The row of the cell that receives the comment.
----------------	--

Element 3: Text

character-value Enter the text that is to appear in the comment.

Message (MSG)

Specifies a message to include in the generated email. CHAR(2048)

Line breaks can be added by placing hex value X'0D25' in the data. See manual section "Adding Line Breaks to the Message" for coding details.

***DEFAULT** The message in the email is generated from the file specification.

***NONE** This parameter does not place a message in the email.

character-value Specify the message placed in the email.

Cc (carbon copy) (CC)

Specifies the email address(es) to which a copy is sent. Up to 300 addresses can be specified. CHAR(128)

Single values

***NONE** An email address is not specified.

Other values (up to 300 repetitions)

***CURRENT** The email address stored in the directory entry associated with the user running the command is used.

***USRID** Specify the directory entry or distribution list that supplies the email address(es). The correct form is: ***USRID:NAME:ADDRESS** where **NAME** is either a directory entry's "User ID" or a distribution list's "List ID" and where **ADDRESS** is either a directory entry's "Address" or a distribution list's "List ID qualifier". The parameter allows lower case data, however this value must be specified all UPPER CASE.

character-value Specify the email address to receive a copy.

Bcc (blind carbon copy) (BCC)

Specifies the email address(es) to which a blind copy is sent. Up to 300 addresses can be specified. CHAR(128)

Single values

***NONE** An email address is not specified.

Other values (up to 300 repetitions)

***CURRENT** The email address stored in the directory entry associated with the user running the command is used.

***USRID** Specify the directory entry or distribution list that supplies the email address(es). The correct form is: ***USRID:NAME:ADDRESS** where **NAME** is either a directory entry's "User ID" or a distribution list's "List ID" and where **ADDRESS** is either a directory entry's "Address" or a distribution list's "List ID qualifier". The parameter allows lower case data, however this value must be specified all UPPER CASE.

character-value Specify the email address to receive a blind copy.

From (originator) (FROM)

Specifies the email address that appears as the **From** on the generated the email. You can use this to control the address used when the recipient replies to the email.

Note: One or more of the special values for this parameter access the system distribution directory to determine an email address based on the implied user profile. If the user profile does not have a directory entry (I.e. the user has not been enrolled), the user name is used to construct an email address. If the user has been enrolled but an email address has not been specified on the directory entry, the user id and address are used to construct an email address. In either case, the constructed address, in all likelihood, is not a valid email address. The email will deliver but recipient replies will be lost (bounce).

***CURRENT** The email address stored in the directory entry associated with the user running the command is used.

character-value Specify the email address of the originator.

Confirmation of delivery (CFMDEL)

Specifies whether a request for a read receipt is sent with the message. Message recipients can choose whether or not to send receipts. If the message recipient agrees to send a read receipt, the receipt will be sent when the message is opened.

***NO** Confirmation of delivery is not requested.
***YES** Confirmation of delivery is requested.
***OBS** Confirmation of delivery is requested as with ***YES** but the obsolete non-standard "Return-Receipt-To" header field is also included in the message. Some mail user/transport agents understand the obsolete field but do not understand the standard "Disposition-Notification-To" supplied by ***YES**.

Reply to (REPLYTO)

Specifies the email address(es) to which replies should be sent when replies should go to an address other than the From (originator) (FROM) parameter or to multiple addresses. Up to 300 addresses can be specified. CHAR(128)

Single values

***NONE** Replies are directed to the address the email is from.

Other values (up to 300 repetitions)

***CURRENT** The email address stored in the directory entry associated with the user running the command is used.
***USRID** Specify the directory entry or distribution list that supplies the email address(es). The correct form is: ***USRID:NAME:ADDRESS** where **NAME** is either a directory entry's "User ID" or a distribution list's "List ID" and where **ADDRESS** is either a directory entry's "Address" or a distribution list's "List ID qualifier". The parameter allows lower case data, however this value must be specified all UPPER CASE.
character-value Specify the email address to which replies should be directed.

Include object (INCOBJ)

Specifies the path name of an additional object (stream file) to include in the generated email message. For example, a stream file containing standard terms and conditions can be included as an additional attachment. A maximum of 64 path names can be specified.

For more information on specifying path names, see *Programming > Control language > CL concepts > IBM i objects > Object naming rules* topic in the IBM i Information Center at <http://publib.boulder.ibm.com/series/>.
CHAR(5000)

Single values

***NONE** No objects are sent.

Element 1: Name

path-name Specify an object path name.

Element 2: Send as

***ATTACH** Send the object as an attached file using MIME and specifying "application/octet-stream".
***TEXTPLAIN** Copy the object into the body of the mail message specifying content type text/plain.
Note: Some servers disregard this request and form an attachment from the message in all cases. Some servers disregard this request for the second and subsequent body parts. If this is the case, try MSG(*NONE).
***TEXTHTML** Copy the object into the body of the mail message specifying content type text/html.
Note: Some servers disregard this request and form an attachment from the message in all cases. Some servers disregard this request for the second and subsequent body parts. If this is the case, try MSG(*NONE).
***ATTACHPDF** Send the object as an attached file using MIME and specifying "application/pdf". Use this value if the attached file contains Adobe's Portable Document Format (pdf) data.

- *ATTACHPS** Send the object as an attached file using MIME and specifying "application/postscript". Use this value if the attached file contains postscript data.
- *NOTE** Same as *TEXTPLAIN which is preferred.

Character encoding of mail (CHRENC)

Specifies the character set used to create the email and MIME headers (the transfer encoding).

- *UTF8** Unicode 8 bit transfer encoding (1208).
- *ISO88591** ISO-8859-1 Latin 1 Western European "8-bit ASCII" (819).
- *ISO88592** ISO-8859-2 ROECE Latin 2 Eastern European (912).
- *ISO88595** ISO-8859-5 Cyrillic (915).
- *ISO88596** ISO-8859-6 Arabic (1089).
- *ISO88597** ISO-8859-7 Greek (813).
- *ISO88598** ISO-8859-8 Hebrew (916).
- *ISO88599** ISO-8859-9 Latin 9 other Latin-using languages (920).
- *BIG5** Traditional Chinese, Taiwan Industry Standard PC Data Mixed for Big5 (950).

Target coded character set id (TRGCCSID)

Specifies the ASCII coded character set identifier (CCSID) that is used to map character data in the generated file. INT(4)

Note: Only *BIFF4 supports this value and it is ignored unless TRANSFORM(*BIFF4) is specified.

- 1252** The default Windows coded character set identifier is used.
- integer*** Specify the coded character set identifier to use.

Source coded character set id (SRCCSID)

Specifies the coded character set identifier (CCSID) used to create the file. INT(4)

Note: Only *BIFF4 supports this value and it is ignored unless TRANSFORM(*BIFF4) is specified.

- *KBDTYPE** The system determines the coded character set identifier value from the QKBDTYPE system value.
- *SYSVAL** The system determines the coded character set identifier value from the QCHRID system value.
- *JOBDFI** The system uses the current job's default coded character set identifier.
- integer*** Specify the coded character set identifier to use.

File sharing (FILESHARE)

Specifies how the generated spreadsheet is secured. Each element corresponds to an Excel setting accessible from the "Save As" dialog. The limitations, and resulting encryption strength vary significantly between *BIFF8 and *BIFF4 and are documented separately.

For *BIFF8

Element 1: Password to open

- character-value*** Specifies the case sensitive password required to open and decrypt the file. If a password is not specified, the file is not encrypted and can be opened by anyone. CHAR(15)
Any character, including DBCS, can be included in the password. The spreadsheet is encrypted using the RC4 algorithm.

Element 2: Password to modify

- character-value*** Specifies the case sensitive password required to update the file. If a password is specified and someone changes the file without the password, that person can save the file only by giving it a different name. If a password is not specified, the file can be updated by anyone. This password does not cause the file to be encrypted. CHAR(15)
Excel-erator restricts this password to a-z, A-Z, 0-9, the space character and symbols !"#%&'()*+,-

./;,<=>?@[^_`{}~. That is the ascii code points from x20-x7E which map directly to UTF8 and the base plane of unicode. With this restriction, the password can be typed by virtually any recipient, without knowing the details of their keyboard or code page of their machine.

Note: The security of Password to modify is notoriously weak.

Element 3: Read-only recommended

- *NO** No recommendation given. CHAR(1) value 'N'.
- *YES** Specifies that users get a read-only (read-only: A setting that allows a file to be read or copied but not changed or saved.) recommendation when they open the file. This does not prevent users from opening the file as read-write so that they can edit and save changes. CHAR(1) value 'Y'.

For *BIFF4

*BIFF4 security is notoriously insecure and may not be suitable for all environments. Password crackers are freely available.

While not a requirement, for best results use a password that contains only characters a-z, A-Z, 0-9, the space character and symbols !"#%&'()*+,-./:;<=>?@[^_`{}~. This insures compatibility with Excel Macintosh edition, for example.

Element 1: Password to open

- character-value** Specifies the case sensitive password required to open and decrypt the file. If a password is not specified, the file is not encrypted and can be opened by anyone. CHAR(15)

Element 2: Password to modify

- character-value** Specifies the case sensitive password required to update the file. If a password is specified and someone changes the file without the password, that person can save the file only by giving it a different name. If a password is not specified, the file can be updated by anyone. This password does not cause the file to be encrypted. CHAR(15)

Element 3: Read-only recommended

- *NO** No recommendation given. CHAR(1) value 'N'.
- *YES** Specifies that users get a read-only (read-only: A setting that allows a file to be read or copied but not changed or saved.) recommendation when they open the file. This does not prevent users from opening the file as read-write so that they can edit and save changes. CHAR(1) value 'Y'.

Column heading format (COLHDGFMT)

Specifies formatting applied to the cells containing column headings. Each element corresponds to an Excel setting accessible by selecting Format > Cells. The values that each element accepts have their usual Excel meanings with one exception: "Alignment-Horizontal" accepts a ***TYPE** special value, which is not available in Excel. When ***TYPE** is specified, the column headings of character fields are given ***LEFT** horizontal alignment while the column headings of numeric fields are given ***RIGHT** horizontal alignment. See Excel's help for additional information. Each element is INT(2).

Single values

- *DEFAULT** Default values are used.

Element 1: Alignment-Horizontal INT(2)

Specifies alignment of text within cells.

- *GENERAL** Cells are given Excel's "General" alignment.
- *TYPE** Alignment is determined by the field's data type: right for numeric fields, left for character fields.
- *LEFT** Cells are given Excel's "Left" alignment.
- *CENTER** Cells are given Excel's "Center" alignment.
- *RIGHT** Cells are given Excel's "Right" alignment.
- *FILL** Cells are given Excel's "Fill" alignment.
- *JUSTIFY** Cells are given Excel's "Justify" alignment.

***CENTERSEL** Cells are given Excel's "Center Across Selection" alignment.

Elements 2-5: Border-Line styles. INT(2)

Specify the Top/Left/Bottom/Right border line styles.

*NONE	Line is removed.
*THIN	Line is thin.
*MEDIUM	Line is medium.
*DASHED	Line is dashed.
*DOTTED	Line is dotted.
*THICK	Line is thick.
*DOUBLE	Line is doubled.
*HAIR	Line is hair.

Elements 6-9: Border-Line colors. INT(2)

Specify the Top/Left/Bottom/Right border line colors.

*SYSTEM	System default color.
*BLACK	Same as *COLOR1. Red=0, Green=0, Blue=0
*WHITE	Same as *COLOR2. Red=255, Green=255, Blue=255
*RED	Same as *COLOR3. Red=255, Green=0, Blue=0
*BRIGHTGREEN	Same as *COLOR4. Red=0, Green=255, Blue=0
*BLUE	Same as *COLOR5. Red=0, Green=0, Blue=255
*YELLOW	Same as *COLOR6. Red=255, Green=255, Blue=0
*PINK	Same as *COLOR7. Red=255, Green=0, Blue=255
*TURQUOISE	Same as *COLOR8. Red=0, Green=255, Blue=255
*DARKRED	Same as *COLOR9. Red=128, Green=0, Blue=0
*GREEN	Same as *COLOR10. Red=0, Green=128, Blue=0
*DARKBLUE	Same as *COLOR11. Red=0, Green=0, Blue=128
*DARKYELLOW	Same as *COLOR12. Red=128, Green=128, Blue=0
*VIOLET	Same as *COLOR13. Red=128, Green=0, Blue=128
*TEAL	Same as *COLOR14. Red=0, Green=128, Blue=128
*GRAY25	Same as *COLOR15. Red=192, Green=192, Blue=192
*GRAY50	Same as *COLOR16. Red=128, Green=128, Blue=128

Element 10: Patterns-Type INT(2)

Specifies the pattern to apply.

*NONE	No pattern is used.
*SOLID	Excel's "Solid" pattern.
*GRAY75	Excel's "75% Gray" pattern.
*GRAY50	Excel's "50% Gray" pattern.
*GRAY25	Excel's "25% Gray" pattern.
*GRAY12	Excel's "12.5% Gray" pattern.
*GRAY6	Excel's "6.25% Gray" pattern.
*STRIPEH50	Excel's "Horizontal Stripe" pattern.
*STRIPEH25	Excel's "Thin Horizontal Stripe" pattern.
*STRIPEV50	Excel's "Vertical Stripe" pattern.
*STRIPEV25	Excel's "Thin Vertical Stripe" pattern.
*STRIPED50	Excel's "Diagonal Stripe" pattern.
*STRIPED25	Excel's "Thin Diagonal Stripe" pattern.
*STRIPEDR50	Excel's "Reverse Diagonal Stripe" pattern.
*STRIPEDR25	Excel's "Thin Reverse Diagonal Stripe" pattern.
*HATCHD75	Excel's "Thick Diagonal Crosshatch" pattern.
*HATCHD50	Excel's "Diagonal Crosshatch" pattern.
*HATCHD38	Excel's "Thin Diagonal Crosshatch" pattern.

***HATCHH38** Excel's "Thin Horizontal Crosshatch" pattern.

Element 11-12: Patterns-Colors INT(2)

Specify the foreground and background pattern colors.

*AUTOMATIC	System default color.
*BLACK	Same as *COLOR1 . Red=0, Green=0, Blue=0
*WHITE	Same as *COLOR2 . Red=255, Green=255, Blue=255
*RED	Same as *COLOR3 . Red=255, Green=0, Blue=0
*BRIGHTGREEN	Same as *COLOR4 . Red=0, Green=255, Blue=0
*BLUE	Same as *COLOR5 . Red=0, Green=0, Blue=255
*YELLOW	Same as *COLOR6 . Red=255, Green=255, Blue=0
*PINK	Same as *COLOR7 . Red=255, Green=0, Blue=255
*TURQUOISE	Same as *COLOR8 . Red=0, Green=255, Blue=255
*DARKRED	Same as *COLOR9 . Red=128, Green=0, Blue=0
*GREEN	Same as *COLOR10 . Red=0, Green=128, Blue=0
*DARKBLUE	Same as *COLOR11 . Red=0, Green=0, Blue=128
*DARKYELLOW	Same as *COLOR12 . Red=128, Green=128, Blue=0
*VIOLET	Same as *COLOR13 . Red=128, Green=0, Blue=128
*TEAL	Same as *COLOR14 . Red=0, Green=128, Blue=128
*GRAY25	Same as *COLOR15 . Red=192, Green=192, Blue=192
*GRAY50	Same as *COLOR16 . Red=128, Green=128, Blue=128

Element 13: Protection-Locked INT(2)

Specifies if the cells are locked. Locking cells or hiding formulas has no effect unless the worksheet is protected.

*YES	Cells are locked.
*NO	Cells are not locked.

Color palette (PALETTE)

Specifies replacements for the default colors included in the spreadsheet's palette. The color palette is made up of the specification for sixteen colors, numbered 1 through 16, and assigned names such as ***BLACK**, ***RED**, etc. Each color in turn is made up of the specification for the amount of red, green, and blue (RGB) components that make up the color. The amount is a number between 0 and 255. The larger the amount, the more of the component present. You can determine the RGB values for a specific color using Excel's Tools > Options > Color > Custom tab. INT(2), INT(2), INT(2) repeated 16 times.

You specify a replacement for a default color by specifying its name and the new RGB values to use. If a color is modified then all references to the color's name, used in other parameters, are also modified. For example, if color ***BLACK** is changed to (255 106 0), color ***BLACK** becomes orange and all parameters that specify ***BLACK** will produce this orange.

Element 1: Color to replace

color-name Specify the name to modify, example ***BLACK**.

Element 2: Red component

integer Specify the red RGB component.

Element 3: Green component

integer Specify the green RGB component.

Element 4: Blue component

integer Specify the blue RGB component.

Signing key (SGNKEY)

Specifies the digital certificate used to sign the email.

The signature included with the email allows the recipient to validate the identity of the sender and provides additional assurance that the email has not been tampered with after it is signed.

A certificate is referenced by specifying the name (Application ID) of an object signing application created using IBM i's Digital Certificate Manager.

*DEFAULT	The certificate previously entered using the CHGXLDFT command is used.
*NONE	No signing operation is performed.
<i>application-id</i>	Specify the application identifier to use in the signing operation.

CSV separator character (CSVSEPCHR)

Specifies the character used to separator fields in the generated file. CHAR(1).

Note: This parameter is ignored for transforms except those that generate Comma Separated Value (CSV).

*COMMA	Values are separated by a ','.
*PERIOD	Values are separated by a '.'.
*PIPE	Values are separated by a ' '.
*SEMICOLON	Values are separated by a ';'.
*SLASH	Values are separated by a '/'.
*TAB	Values are separated by a horizontal tab.
<i>character-value</i>	Specify the character.

To (distribution list) (TOUSRID)

Note: If this parameter is specified and the **To (recipient) (TO)** parameter is not specified, the entered value overrides the default value of the **To (recipient) (TO)** parameter.

Specifies the Distribution list or network user to receive the email. CHAR(8), CHAR(8)

Single values

*NONE	A network user or distribution list is not specified.
--------------	---

Element 1: User ID

character-value Specify the user ID (DEN) of the network user. CHAR(8)

Element 2: Address

character-value Specify the address (DGN) of the network user. CHAR(8)

Examples

Example 1:

```
SNDFEXCEL  SNDF((CUSTOMER)) TO((billg@acme.com))
```

This command converts file "CUSTOMER" into an Excel spreadsheet with the name "CUSTOMER.XLS". The spreadsheet is sent as an email attachment to billg@acme.com.

Example 2:

```
SNDFEXCEL  SNDF((INVOICE) (CUSTOMER))
           TO((billg@acme.com))
```

This command converts files "INVOICE" and "CUSTOMER" into separate Excel spreadsheets with the names INVOICE.XLS and CUSTOMER.XLS respectively. These are sent as attachments to an email sent to billg@acme.com.

Error messages

Parameter dependencies

XL17001	A To (recipient) or a To (distribution list) must be specified.
XL17002	A To (recipient) or a To (distribution list) can be specified, but not both.
XL17006	When TRANSFORM(*BIFF4) is specified COLHDG(*COLHD1) and COLHDG(*COLHD1BLD) can not be specified.
XL17007	When PRTHEADER() is specified TRANSFORM(*BIFF8/*BIFF4/*XMLSS/*OOXML) must be specified.
XL17008	When PRTFooter() is specified TRANSFORM(*BIFF8/*BIFF4/*XMLSS/*OOXML) must be specified.
XL17008	When FONT() is specified TRANSFORM(*BIFF8/*BIFF4/*XMLSS/*OOXML) must be specified.
XL17008	When COMMENT() is specified TRANSFORM(*BIFF8/*BIFF4/*XMLSS/*OOXML) must be specified.
XL17008	When TRGCCSID() is specified TRANSFORM(*BIFF4) must be specified.
XL17008	When SRCCSID() is specified TRANSFORM(*BIFF4) must be specified.
XL17008	When FILESHARE() is specified TRANSFORM(*BIFF8/*BIFF4) must be specified.
XL17008	When COLHDGFMT() is specified TRANSFORM(*BIFF8/*BIFF4/*XMLSS/*OOXML) must be specified.
XL17008	When PALETTE() is specified TRANSFORM(*BIFF8/*BIFF4/*XMLSS/*OOXML) must be specified.
SCV7001	CSV Separator character ',' required with TRANSFORM(*CSVRFC).

Verify/Set Up Local SMTP (VFYLOCAL)

Where allowed to run: All environments (*ALL)

Threadsafe: No

The Verify/Set Up Local SMTP (VFYLOCAL) command verifies or sets up SMTP on the local system.

Parameters

Keyword	Description	Choices	Notes
SETUP	Make changes to system	<u>*NO</u> , *YES, Y, N	Optional, Positional 1

Make changes to system (SETUP)

Specifies the whether the command makes changes to the system.

- *NO** The command does not make changes to the local system.
- *YES** The command makes changes to the local system.

Examples

Example 1:

```
VFYLOCAL    SETUP (*NO)
```

This command verifies that SMTP is set up correctly on the local system.

Example 2:

```
VFYLOCAL    SETUP (*YES)
```

This command sets up SMTP on the local system.

Verify/Set Up Mail Router (VFYROUTER)

Where allowed to run: All environments (*ALL)

Threadsafe: No

The Verify/Set Up Mail Router (VFYROUTER) command verifies or sets up a remote mail router for use by the local system.

Parameters

Keyword	Description	Choices	Notes
RMTSYS	Remote system	Character value, *ROUTER , *INTNETADR	Optional, Positional 1
INTNETADR	Remote internet address	Character value, *RMTSYS , *ROUTER	Optional, Positional 2
SETUP	Make changes to system	*YES, *NO , Y, N	Optional, Positional 3

Remote system (RMTSYS)

Specifies the remote system name of the host with which the Verify/Set Up Mail Router operation takes place. To be successful, the name must be valid, and the remote system must be able to communicate with the local system.

- *ROUTER** The name of the configured SMTP mail router is used.
- *INTNETADR** The INTNETADR parameter is used.
- character-value** Specify the remote system name to use.

Remote internet address (INTNETADR)

Specifies the remote internet address. The internet address is specified in the form **nnn.nnn.nnn.nnn**, where **nnn** is a decimal number ranging from 0 through 255. An internet address is not valid if it has a value of all binary ones or all binary zeros for the network identifier (ID) portion or the host ID portion of the address. If the internet address is entered from a command line, enclose the address in apostrophes.

- *RMTSYS** The internet address of the specified remote system is used.
- *ROUTER** The internet address of the configured SMTP mail router is used.
- character-value** Specify the internet address to use.

Make changes to system (SETUP)

Specifies the whether the command makes changes to the system.

- *NO** The command does not make changes to the local system.
- *YES** The command makes changes to the local system.

Examples

Example 1:

```
VFYROUTER RMTSYS (*ROUTER) SETUP (*NO)
```

Command verifies that the currently configured mail router is set up and operating correctly.

Example 2:

```
VFYROUTER RMTSYS (sys1.widget.com)
           INTNETADR (192.168.1.2) SETUP (*YES)
```

This command sets up sys1.widget.com at address 192.168.1.2 as the mail router for this System i.

Error messages

Parameter dependencies

MSU7011 RMTSYS(*INTNETADR) and INTNETADR(*RMTSYS) are mutually exclusive.

Chapter 8 Trouble-Shooting

What's In This Chapter

This chapter provides information and procedures useful for correcting or reporting Excel-erator problems. The chapter:

- Describes general trouble-shooting.
- Describes software installation problems.
- Describes Excel file problems.
- Describes general mail delivery problems.
- Describes MSF specific delivery problems.
- Describes SMTP specific delivery problems.

General Trouble-Shooting

If a command from Excel-erator fails to run to completion or if the results you receive are different from those expected, perform these items:

- Check the detailed messages in your job log:
 1. Run the DSPJOBLOG command.
 2. Press F10 to display detailed messages.
 3. Locate the messages related to the error.
 4. Place your cursor on each message in turn and press F1.
 5. Take any corrective actions suggested by the messages.
- Download the current cumulative PTF package from www.gumbo.com.
- Check the bottom of the PTF page at www.gumbo.com for IBM PTFs that may be required.
- Review the detailed trouble shooting procedures in this chapter for solutions related to your problem.

If you are unable to correct the problem, prepare a problem report and contact your service provider.

Software Installation Problems

This section describes problems, causes, and solutions specific to software installation.

- Installation Generates "Directory not registered. (C G)"

Symptom	During installation inquiry message id CPA3DE4 "Directory not registered. (C G)" is issued.
Cause	IBM i has lost the relationship between the product and the directory and hence the message.
Solution	You can safely take a "G" to this message. You will receive the message 3 times.

- Installation Fails

Symptom	Installation fails and diagnostic message id CPF9898 "Unable to clear old release. Is the software being used?" appears in the job log. Or, when the installation verification option is run, verification fails with diagnostic message id CPD0C2E appearing in the job log.
Cause	This usually arises from attempting to install a new release over an old release while objects in the old release are in use.
Solution	End the jobs that are holding locks on (using) objects from the old release and perform the installation again.

- Installation Fails or Installation Verification Fails

Symptom	Installation or installation verification fails and messages in the job log do not help in recovering.
Cause	The software is not installed correctly or the installation is damaged. This can be caused for a variety of reasons including renaming of libraries, directories, or objects that make up the product.
Solution	<p>Get the system to a stable consistent state by completely removing the product then re-installing it by performing the following:</p> <ol style="list-style-type: none"> Delete the licensed program by running: <pre>DLTLICPGM LICPGM(2A55XL1) RLS(*ALL) OPTION(*ALL)</pre> <p>Note: It is okay if this fails with diagnostic CPD3D91 "Product 2A55XL1 option *ALL release *ALL not installed."</p> Delete the product's library by running: <pre>DLTLIB LIB(XLERATOR)</pre> <p>Note: It is okay if this fails with escape CPF2110 "Library XLERATOR not found."</p> Delete the product's directories by running: <pre>RMVDIR DIR('/Gumbo/ProdData/2A55XL1/doc') RMVLNK(*YES) RMVDIR DIR('/Gumbo/ProdData/2A55XL1/tmp') RMVLNK(*YES) RMVDIR DIR('/Gumbo/ProdData/2A55XL1') RMVLNK(*YES)</pre> <p>Note: It is okay if these fail with escape CPFA0A9 "Object not found. ...". But if any of these fail because a directory is not empty, delete the contents using WRKLNK.</p> <p>If there are no other GUMBO products installed:</p> <pre>RMVDIR DIR('/Gumbo/ProdData') RMVDIR DIR('/Gumbo')</pre> Rebuild IBM i's internal licensed program information by running: <pre>CALL PGM(QSYS/QSZRECOV)</pre> <p>Note: This takes several minutes depending on machine size.</p> Install the product according to the instructions in the Installation chapter. Enter your authorization code.

XLS File Problems

This section describes problems, causes, and solutions specific to Excel Format (XLS) files.

- Large Character Fields Are Truncated

Symptom	The file is generated and displays without error however, some large character fields are truncated.
Cause	BIFF4 imposes a 255 byte limit on the length of character fields.
Solution	Switch to BIFF8, which lifts the limit on field size.

General Mail Delivery Problems

This section describes common problems, causes, and solutions for general mail delivery problems. They are listed roughly in the order in which you should proceed. During general mail delivery trouble shooting you should send tests to yourself. Once this works properly, you can move on.

The bulk of the entries in this section are derived from trouble shooting performed by or with customers and in some sense presume that you have an "average" installation. The "average" installation is System i connected to a LAN with the post office (a.k.a. mail router) on a LAN attached PC running Exchange, Notes or GroupWise with or without a connection to the internet at large. At the "average" installation this is the first application to generate email from the System i. Some of the entries in this section may not apply to your situation.

- Source Of Problem Is Unknown

Symptom	The send operation runs to completion but no mail arrives.
Cause	The problem may be with the mail router or with IBM i, but the source is unknown.

Solution Run PINGMAIL to generate a test message to your email address and directly deliver it to the mail router by passing IBM i's mail machinery entirely:

Note: Substitute the name of your mail router for the value "mail_router" and substitute your email address for the value "you@domain.com" in the following command.

```
PINGMAIL RMTSYS(mail_router)
SMTPNAME(you@domain.com)
```

If you receive the test message, the mail router is working correctly and an IBM i issue is indicated. In particular, if the rest of the entries in this section do not correct the problem, you may have a DNS issue.

If you do not receive the test message then there is a problem with the mail router. You may be able to get an indication of the problem by reviewing the SMTP conversation, which appears in your joblog. Run DSPJOBLOG, press F10 and page back for details.

- IBM i Servers Are Down

Symptom The send operation runs to completion but no mail arrives.

Cause The IBM i servers responsible for mail delivery may be down, particularly if the System i has been IPLed.

Solution Rerun VFYLOCAL to verify that all local servers are up and running:
VFYLOCAL SETUP(*NO)

If local verification fails, run:
VFYLOCAL SETUP(*YES)

- Mail Router Is Not Processing Mail

Symptom The send operation runs to completion but no mail arrives.

Cause The mail router responsible for mail delivery may be down, or not accepting mail from IBM i.

Solution Rerun VFYROUTER to verify that the mail router is up and running:
VFYROUTER SETUP(*NO)

If mail router verification fails, run:
VFYROUTER SETUP(*YES)

- Mail Router Refuses Mail with "Funny" Originator Address

Symptom The send operation runs to completion but no mail arrives. Or mail arrives for some users but not all users, for example for all but AOL accounts.

Cause An email address is not assigned to your directory entry and the mail router does not like the "funny" address IBM i generates for the originator's address.

Solution Assign your email address to your system distribution directory entry: (assume for this example that your "User ID and Address" are "BILLG S1234567" and you "real" email address is "billg@acme.com")
CHGDIRE USRID(BILLG S1234567)
MSFSRVLVL(*SYSMS) PREFADR(*SMTP)
USRDFNFLD((SMTPAUSRID SMTP 'billg')
(SMTPDMN SMTP 'acme.com'))

Note: If you are a local Domino for IBM i user substitute MSFSRVLVL(*DOMINO) for MSFSRVLVL(*SYSMS).

- SMTP Servers Require Reinitialization

Symptom The send operation runs to completion but no mail arrives.

Cause IBM i's SMTP servers may need to reinitialize. This is undocumented but our experience and discussions with IBM i's SMTP architect confirm this.

Solution Reinitialize IBM i's SMTP servers:
INZLOCAL SMTP (*YES) SMTPPURGE (*NO)
MSF (*NO) MSFPURGE (*NO)

- SMTP Servers Are Clogged With Junk

Symptom The send operation runs to completion but no mail arrives.
Cause IBM i's SMTP server may contain dead letters or other junk that it can not deliver. This can be the result of previous attempts to set up mail on the system.

Solution Clean out IBM i's SMTP server:

Note: Only perform this procedure if you are sure there is no valid deliverable mail in the SMTP server.

Note: This procedure should be required at most once per system during initial set up.

```
INZLOCAL SMTP (*YES) SMTPPURGE (*YES)
MSF (*YES) MSFPURGE (*YES)
```

- Mail Server Framework Is Reporting Errors

Symptom The send operation runs to completion but no mail arrives.

Cause IBM i's Mail Server Framework jobs may be unable to process mail and are reporting errors.

Solution Review job logs for the Mail Server Framework jobs:

1. Work with active jobs by running the following command:
WRKACTJOB
2. Page down to the QSYSWRK subsystem.
3. Locate the job or jobs with the name QMSF and repeat the following steps for each job.
4. Display the job by using option 5 and pressing enter.
5. Display the job log by selecting option 10 and pressing enter.
6. Display detailed messages by pressing F10.
7. You should see a job started (CPF1124) and job submitted (CPI1125) message. If there are no other messages, the Mail Server Framework is not reporting errors. (End of procedure).
8. Display detailed information for each additional message by placing your cursor on the message and pressing F1.
9. Take any corrective action specified in the messages.
10. See the MSF Specific Delivery Problems section of this chapter.

- Mail Server Framework Is Ending Abnormally

Symptom The send operation runs to completion but no mail arrives.

Cause IBM i's Mail Server Framework jobs may be unable to process mail and are ending abnormally.

Solution Review job logs for the Mail Server Framework jobs:

1. Locate job logs for Mail Server Framework jobs that have ended by running the following command:
WRKSPLF SELECT (QMSF)

If there are no spooled output files, the Mail Server Framework is not ending abnormally (end of procedure).
2. Page down to the end of the list of spooled files.
3. Display the date and time of the spooled files by pressing F11. If there are no recent spooled files, the Mail Server Framework is not ending abnormally (end of procedure).
4. For each recent job log repeat the following steps:
5. Display the job log by using option 5 and pressing enter.
6. Review the job log for diagnostic and escape messages.
7. Take any corrective action specified in the messages.
8. See the MSF Specific Delivery Problems section of this chapter.

- SMTP Servers Are Reporting Errors

Symptom	The send operation runs to completion but no mail arrives.
Cause	IBM i's SMTP server jobs may be unable to process mail and are reporting errors.
Solution	Review job logs for the SMTP server jobs: <ol style="list-style-type: none"> 1. Work with active jobs by running the following command: <code>WRKACTJOB</code> 2. Page down to the QSYSWRK subsystem. 3. Locate the 4 SMTP server jobs with names that start with QTSMTMP*. Repeat the following steps for each job. 4. Display the job by using option 5 and pressing enter. 5. Display the job log by selecting option 10 and pressing enter. 6. Display detailed messages by pressing F10. 7. You should see a job started (CPF1124) and job submitted (CPI1125) message. If there are no other messages, the Mail Server Framework is not reporting errors. (End of procedure). 8. Display detailed information for each additional message by placing your cursor on the message and pressing F1. 9. Take any corrective action specified in the messages. 10. See the SMTP Specific Problems section of this chapter.

- SMTP Servers Are Ending Abnormally

Symptom	The send operation runs to completion but no mail arrives.
Cause	IBM i's SMTP server jobs may be unable to process mail and are ending abnormally.
Solution	Review job logs for the SMTP server jobs: <ol style="list-style-type: none"> 1. Locate job logs for SMTP server jobs that have ended by running the following command: <code>WRKSPLF SELECT(QTCP)</code> If there are no spooled output files, the SMTP server jobs are not ending abnormally (end of procedure). 2. Page down to the end of the list of spooled files. 3. Display the date and time of the spooled files by pressing F11. If there are no recent spooled files, the SMTP server jobs are not ending abnormally (end of procedure). 4. For each recent job log repeat the following steps: 5. Display the job log by using option 5 and pressing enter. 6. Review the job log for diagnostic and escape messages. 7. Take any corrective action specified in the messages. 8. See the SMTP Specific Problems section of this chapter.

MSF Specific Delivery Problems

This section describes problems, causes, and solutions specific to IBM i's Mail Server Framework.

- MSF Job Log Contains QTCPTMM/ATTABOX Messages

Symptom	A QMSF job is complaining about a directory such as QTCPTMM/ATTABOX.
Cause	IBM i's MSF jobs depend on specific directories in the Integrated File System which are added by installing the TCP/IP Utilities and may have been deleted.
Solution	Check the existence of the TCP/IP related directories and reinstall them if they are missing by: <ol style="list-style-type: none"> 1. Run the WRKLNK command and locate the QTCPTMM directory. 2. Display QTCPTMM's contents using option 5. 3. Verify that subdirectories ATTABOX, ENCODE, MAIL, SMTPBOX and TMP exist. 4. If directories are missing continue with this procedure otherwise end of procedure. 5. Use the DLTLICPGM command to remove the TCP/IP Utilities. 6. Use the RSTLICPGM command to reinstall the TCP/IP Utilities.

- MSF Job Log Contains "System storage threshold exceeded" Message

Symptom	A QMSF job complains that "System storage threshold exceeded".
----------------	--

- Cause** IBM i's MSF jobs stop processing mail when amount of disk space used rises above a set percentage. IBM i ships with this value set to 90%.
- Solution** Either free disk space by deleting unused items or bump the threshold value with this procedure:
1. Run the STRSST command and select option 3 Work with disk units.
 2. Select option 2 Work with disk configuration.
 3. Select option 3 Work with ASP threshold.
 4. Use 1=Select for the appropriate ASP (usually ASP 1).
 5. Press F1=Help to review help for the Change Storage Threshold display.
 6. Change the ASP threshold to 95% or a comfortable value for your installation.

SMTP Specific Delivery Problems

This section describes problems, causes, and solutions specific to IBM i's SMTP servers.

- SMTP Retries Set To Zero

- Symptom** The send operation runs to completion but no mail arrives, or mail arrives for a while then stops until the next IPL.
- Cause** The mail router is periodically slow or unavailable and IBM i's SMTP attributes for retries are set too low or set to zero.
- Solution** Increase the retry values to give the mail router more chances at fielding the incoming mail:
1. Prompt the CHGSMTPA command.
 2. Increase the number of retries for the retries by minute parameter.
 3. Increase the number of retries for the retries by day parameter.
 4. Press enter.

- Multiple Garbled Email Messages Arrive

- Symptom** Multiple messages arrive for a send operation and the messages are garbled.
- Cause** IBM i's SMTP is splitting the messages.
- Solution** Turn off message splitting entirely by changing the POP attributes:
 CHGPOPA MSGSPLIT (*NOMAX)

- Time On Mail Is Incorrect

- Symptom** Mail delivers but contains the wrong time.
- Cause** IBM i's QTIMZON system value is not set.
- Solution** See Manual Mail Set Up Steps You May Need To Perform section of the Set Up chapter for instructions to correct this value.

Appendix A Process Descriptions

What's In This Appendix

This appendix provides detailed descriptions of the processing performed by Excelerator's mail set up and verification programs. In highly secure environments, it may be against policy to allow third party software to change your system. If this is your situation, you can perform these steps manually. The appendix details:

- Processing Performed During SMTP Verification
- Processing Performed During SMTP Set Up
- Processing Performed During Mail Router Verification
- Processing Performed During Mail Router Set Up

Processing Performed During SMTP Verification

The following verification steps are performed by the Verify/Set Up Local SMTP (VFYLOCAL) command when SETUP(*NO) is specified.

Note: No changes are made to your system during verification.

- Verify that TCP Utilities have been installed on the system.

The system is checked to insure that library QTCP exists. If the library is found then the TCP Connectivity Utilities have been installed on the system.

- Verify that the SMTP distribution queues are present.

The system is checked for the existence of QSMTPQ distribution queue.

- Verify that a host and domain name have been configured for the system.
 - If the host name is blank, verification fails.
 - If the domain name is blank, verification fails.
- Verify that the system distribution directory is searchable.

A search is attempted on the system distribution directory.

- Verify that the IBM i Mail Server is active.

The system is checked for an active job with the job name QMSF. If one or more QMSF jobs are active then the Mail Server is active.

- Verify that TCP is active.

The system is checked for an active job with the job name QTCPWRK (before V6 JOB QTCPWP). If job is active then TCP is active.

- Verify that TCP loopback is operating correctly.

The TCP interfaces are searched to locate the *LOOPBACK IP address. The *LOOPBACK interface is started if it is not active and its IP address is PINGed to verify that TCP is operating correctly.

- If the *LOOPBACK interface is not found, verification fails.
- If the *LOOPBACK interface is not active and can not be started, verification fails.
- If the *LOOPBACK interface can not be PINGed, verification fails.

The *LOOPBACK interface is ended if it was started by the verification program.

- Verify that a TCP interface is defined.

The TCP interfaces are searched to locate one or more IP addresses (excluding *LOOPBACK).

- If no interfaces are found, verification fails.
- Verify that active TCP interfaces are reachable.

The TCP interfaces are searched to locate one or more IP addresses (excluding *LOOPBACK). Each interface is contacted (PINGed) to verify the connection.

- If an interface is not active, verification fails.
- If an interface can not be contacted, verification fails.
- Verify that the SMTP server is active.

The system is checked for an active job with the job name QTSMTPSRVR or QTSMTPSRVD. If either job is active then the SMTP server is active.

- Verify that this host's IP address can be reached by SMTP.
 - Retrieve the host and domain names for this system.

If the host name is blank, verification fails.

- Verify TCP/IP connection to the host name.

If the host is contacted, verification is complete and no further processing is performed.

- Verify TCP/IP connection to the host.domain name.

If the host.domain name can not be contacted, verification fails.

- Verify that message splitting has been turned off.

The current setting can not be retrieved so no test is performed and it is assumed that splitting has not been turned off yet.

After all tests are completed, a message summarizing the results is issued.

Processing Performed During SMTP Set Up

The following set up work is performed by the Verify/Set Up Local SMTP (VFYLOCAL) command when SETUP(*YES) is specified.

- If the TCP utilities have not been installed on the system.
 - Manual intervention is required to install the utilities. Automatic set up can not perform the installation.
- If QSMTPQ distribution queue is not found.

- Create the distribution queue using the Add Distribution Queue command:

```
ADDSTQ      DSTQ(QSMTPQ) RMTLOCNAME(TCPIPLOC)
           DSTQTYPE(*RPDS)
```

- If a host or domain name have not been configured.
 - Manual intervention is required to configure a host and domain name. Use option 12 (Change local domain and host names) of the Configure TCP/IP (CFGTCP) command. Automatic set up can not perform the change.
- If the system distribution directory entry can not be searched.
 - The directory is changed to allow searches using the Change System Directory Attributes command:

```
CHGSYSDIRA  ALWSCH(*YES)
```

- If the IBM i Mail Server is not active.
 - Start the Mail Server using the STRMSF command:

```
STRMSF
```

- If TCP is not active.
 - Start TCP using the STRTCP command:

```
STRTCP
```

- If TCP loopback is not operating correctly.
 - If missing, *LOOPBACK interface is added using command:

```
ADDTCPIFC  INTNETADR('127.0.0.1') LIND(*LOOPBACK) +
           SUBNETMASK('255.0.0.0') MTU(576)
```

- If loopback PING fails:

Manual intervention is required to correct the problem, which is beyond the scope of set up.

- If no TCP interfaces are found.

Manual operation is required to add an interface using the ADDTCPIFC command.

- If a TCP interface can not be contacted.

Manual operation is required to correct the problem. If the interface can not be contacted because it is not active, start the interface using the STRTCPIFC command.

- If the SMTP server is not active.
 - Start the SMTP server using the STRTCPSVR command:

```
STRTCPSVR  SERVER(*SMTP)
```

- If the host's IP address can not be reached by SMTP.

- If system is using a remote name server, set up fails.

Manual operation required. Contact the remote name server's administrator to add this system's host name.

- If multiple TCP interfaces are found, set up fails.

Manual operation required. Add this system's name to IBM i's host table using the ADDTCPHTE command.

- If no TCP interfaces are found, set up fails.

Manual operation required. Add a TCP interface using the ADDTCPIFC command.

- An entry is added for this host using the Add TCP Host Table Entry command:

```
ADDTCPHTE  INTNETADR(&INTERNET) HOSTNAME((&HOST)) +
           TEXT('Entry Added By Gumbo Auto TCP/IP +
              Config')
```

- If message splitting has not been turned off.
 - Message splitting is turned off

The POP attributes are changed:

```
CHGPOPA    MSGSPLIT (*NOMAX)
```

After all steps are completed, a message summarizing the results is issued.

Processing Performed During Mail Router Verification

The following verification steps are performed by the Verify/Set Up Mail Router (VFYROUTER) command when SETUP(*NO) is specified.

Note: No changes are made to your system during verification.

- Verify that TCP is active.

The system is checked for an active job with the job name QTCPWRK (before V6 JOB QTCPIP). If job is active then TCP is active.

- Resolve system names and internet addresses for command parameters and current mail router.
 - Verify domain name server.

If a domain name server is configured, it is tested to insure that it is responding. If it does not respond, verification fails.

- Retrieve currently configured mail router name and IP
- Resolve internet address parameter.

If a special value was specified, it is resolved. If it can not be resolved, verification fails.

- Resolve remote system parameter.

If a special value was specified, it is resolved. If it can not be resolved, verification fails.

- Edit the resulting names and IPs for conflicts.
 - Edit remote system and internet address IP.

If the IP of the remote system is different than the internet address, verification fails.

- Edit remote system and internet address names.

If the name of the internet address is different than the remote system name, verification fails.

- Edit current mail router and internet address IP.

If the IP of the current mail router is different than the internet address, verification fails.

- Verify that the internet address is responding.

The internet address is PINGed to insure that it is reachable and responding. If it is not, verification fails.

- Verify that the internet address is accepting SMTP mail.

The internet address is tested to insure that it is accepting SMTP mail from this System i. If it is not, verification fails.

- Verify that remote system can be located in the host table.

If a host table entry is required and not present, verification fails.

- Verify that the mail router is configured.

If the remote system is not configured as the mail router, verification fails.

After all tests are completed, a message summarizing the results is issued.

Processing Performed During Mail Router Set Up

The following set up work is performed by the Verify/Set Up Mail Router (VFYROUTER) command when SETUP(*YES) is specified.

- If TCP is not active.
 - Start TCP using the STRTCP command:

```
STRTCP
```

- If system name and internet address resolution fails.

- If a domain name server is configured but not responding.

Manual intervention required. Either insure that the configured domain name server is available or remove the domain name server from IBM i's configuration using option 13 of the CFGTCP menu.

- If the internet address parameter can not be resolved.

Manual intervention required to correct the internet address parameter.

- If the remote system parameter can not be resolved.

Manual intervention required to correct the remote system parameter.

- If the resolved names and IPs for conflicts.

- If the remote system and internet address IPs are different.

Manual intervention required to correct the parameters.

- If the remote system and internet address names are different.

Manual intervention required to correct the parameters.

- If the current mail router and internet address IPs are different.

Manual intervention required. Either correct the parameters or remove the currently configured mail router by running the following command:

```
CHGSMTPA MAILROUTER (*NONE)
```

- If the internet address is not responding.

Manual intervention required. Either correct the internet address or make the system at that address ready.

- If the internet address is not accepting SMTP mail.

Manual intervention required. Either correct the internet address, or contact the system's administrator and request that the system accept SMTP from IBM i. The words you use to request this differ depending on the software running on the remote system:

- For Microsoft's Exchange Server request that the "Internet Mail Connector" be configured and started.
- For Lotus' cc:Mail request that the "Link to SMTP" be configured and started.
- For all others request that the "SMTP gateway" be configured and started.

- If the remote system can not be located in the host table.

Add an entry using the Add TCP/IP Host Table Entry (ADDTCPHTE) command:

```
ADDTCPHTE INTNETADR(&INTNETADR) HOSTNAME((&RMTSYS)) +
          TEXT('Mail router added by Gumbo +
              automatic configuration')
```

- If the mail router is not configured.

Configure the mail router using the Change SMTP Attributes (CHGSMTPA) command:

```
CHGSMTPA MAILROUTER (&RMTSYS) FIREWALL (*YES)
```

Note: The FIREWALL() parameter is probably misnamed. When set to *YES, it instructs IBM i to send all email through the mail router. When set to *NO, IBM i tries to deliver the email directly. If this fails, it gives the email to the mail router for delivery.

After all steps are completed, a message summarizing the results is issued.

Appendix B Notices

Notices

© Copyright Gumbo Software, Inc. 2001, 2011. All Rights Reserved.

Portions of this software are used with permission and:

- Copyright © 1991-2, RSA Data Security, Inc. All rights reserved.
- Copyright © April 29, 1997 Kalle Kaukonen. All Rights Reserved.
- Copyright © 1995-1997 Peter Mattis, Spencer Kimball and Josh MacDonald
- Copyright © 1998-1999, 2000-2001 Tim Janik and Red Hat, Inc.
- Copyright © 2000 Konstantin Chuguev. All rights reserved.
- Copyright © 2002-2006 Jody Goldberg (jody@gnome.org)
- Copyright © 1998-2000 Carnegie Mellon University. All rights reserved.
- Copyright © 2002, 2003, 2004 Simon Josefsson
- Copyright © 1998-2006 The OpenSSL Project. All rights reserved.
- Copyright © 1995-1998 Eric Young (eay@cryptsoft.com) All rights reserved.
- Copyright © 1998-2003 Daniel Veillard. All Rights Reserved.

For additional information see, file XLERATOR/COPYRIGHT.

Appendix C Order Form

Name _____
Company _____
Address _____
City/State/Zip _____
Country _____
Phone _____
Email _____

I have read and agree with the Excel-erator Software License Agreement. I am ordering the following licenses:

System Wide License	-- or --	Partition License		
	Proc.		Prt.	Proc.
-- Serial Number ---	Group	-- Serial Number ---	No.	Count
_____	_____	_____	_____	_____
_____	_____	_____	_____	_____
_____	_____	_____	_____	_____

See the Price List for pricing information. The current Price List is available at www.gumbo.com. License price includes one year of maintenance services. Add the amount shown on the price list for each additional year of maintenance services. In Washington state include sales tax (your local rate or 9.5%).

Licenses _____
Maintenance _____
In WA state, add sales tax _____
Total enclosed _____
Signature _____ Date _____
Title _____

Make checks payable to:

GUMBO
Software, Inc.

809 W Howe St
Seattle, WA 98119
United States of America
Phone: 206-284-5078
Email: support@gumbo.com
Web: www.gumbo.com

Rev: 2009/04/14

Appendix D License Agreement

License

Gumbo Software, Inc. grants to the purchaser, permanent license to use Excel-erator on the specified serial number and processor group IBM System i. For system licenses the grant is specific to the system as a whole. For partition licenses the grant is specific to a partition number (ID) and maximum processing capacity. This license is not transferable and not exclusive.

Warranty

Gumbo Software, Inc. makes no warranty, either expressed or implied, with respect to Excel-erator, its merchantability or its fitness for any particular purpose. Excel-erator software and documentation are provided on an "AS IS" basis.

Liability

Gumbo Software, Inc. assumes no responsibility for the use of Excel-erator. Purchaser agrees that Gumbo Software, Inc.'s liability under any circumstances shall not exceed the charges paid by purchaser.

Updates

Gumbo Software, Inc. may from time to time update Excel-erator to correct defects or add enhancements. Purchaser will receive updates for a period of one year from date of purchase.

Rev: 2001/09/22